

# FULLY AUTOMATIC STRAPPING MACHINE

■ Operation / Technical Manual

■ Parts List

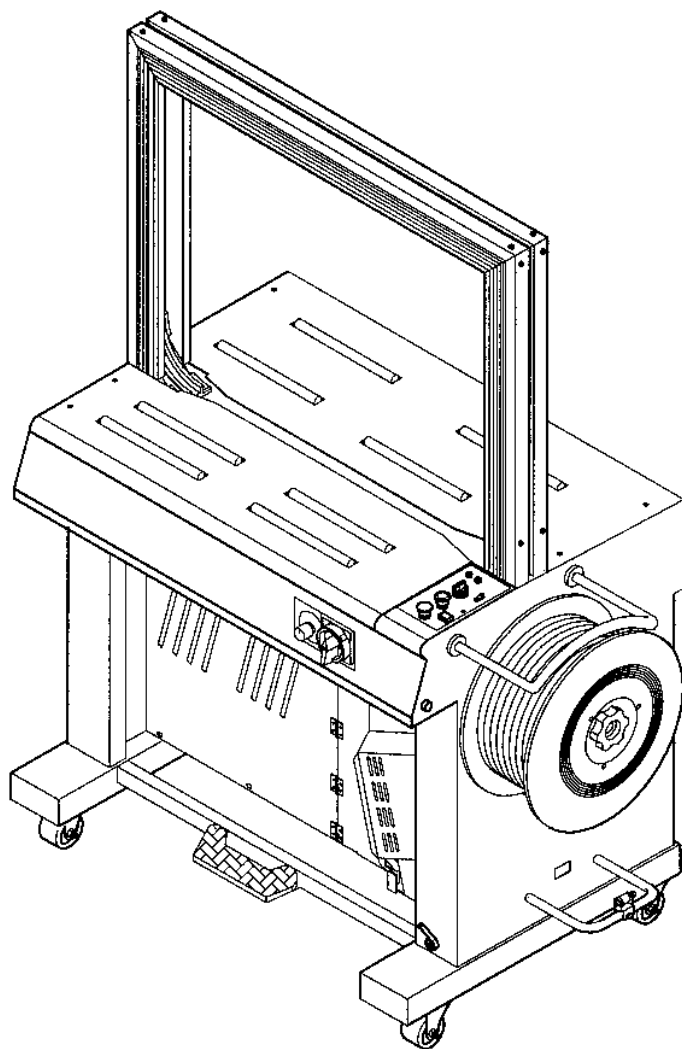

Carefully read Safety Information and instructions in  
this Manual before operating machine.

2007/06

## INDEX

	PAGE
1. PREFACE & SPECIFICATION.....	1
2. ARCH INSTALLATION.....	2
3. MAJOR COMPONENTS AND STRUCTURE.....	3
4. STRAP THREADING PROCEDURE.....	4-5
5. CONTROL PANEL.....	6
6. TENSION ADJUSTMENT.....	7
7. TEMPERATURE ADJUSTMENT.....	8
8. POOL BOX ADJUSTMENT.....	9
9. FORWARDING & REVERSING ROLLER ADJUSTMENT.....	10
10. REMOVING & ASSEMBLING OF STRAP GUIDE ASSEMBLY.....	11
11. PROPER P. P. STRAP ALIGNMENT.....	12
12. CONTROL BOX.....	13
13. TIME SETTING & ADJUSTMENT.....	14
14. TIMING ADJUSTMENT .....	15
15. SYMBOL OF ELECTRIC ACCESSORY OF DRIVE UNIT.....	16
16. CLEANING & MAINTENANCE.....	17
17. EASY TROUBLE –SHOOTING GUIDE.....	18-19
18. ELECTRICAL SCHEMATIC.....	20-24

## PREFACE

This economic and reliable mode of machine features many excellent characters. It is installed with the latest arch design with low-level noise emission and a new all-closed-style design on the arch frame. Besides that, the fully automatically machine is easy to operate the complicated process of setting and feeding of straps by simply using buttons and knobs on panels. It also offers three ways to do strapping work including easy manual operation, fixed and foot pedal operation conforms to ergonomics and ball switch operation. In addition, the proximity lamp shows the light signal to tell whether the strap is fed properly or not. Strapping work can be done within 25 seconds of warm-up and the sealing head will automatically reheat itself after strapping 5 times. Other notable advantages of the machine, easy to maintain and repair, are the flexibility for users to get their ideal machine by setting inner control for the automatic-stopping motor for saving energy and cooling delayed device and by easily controlling outer and inner electronic device to set up the tension strength.

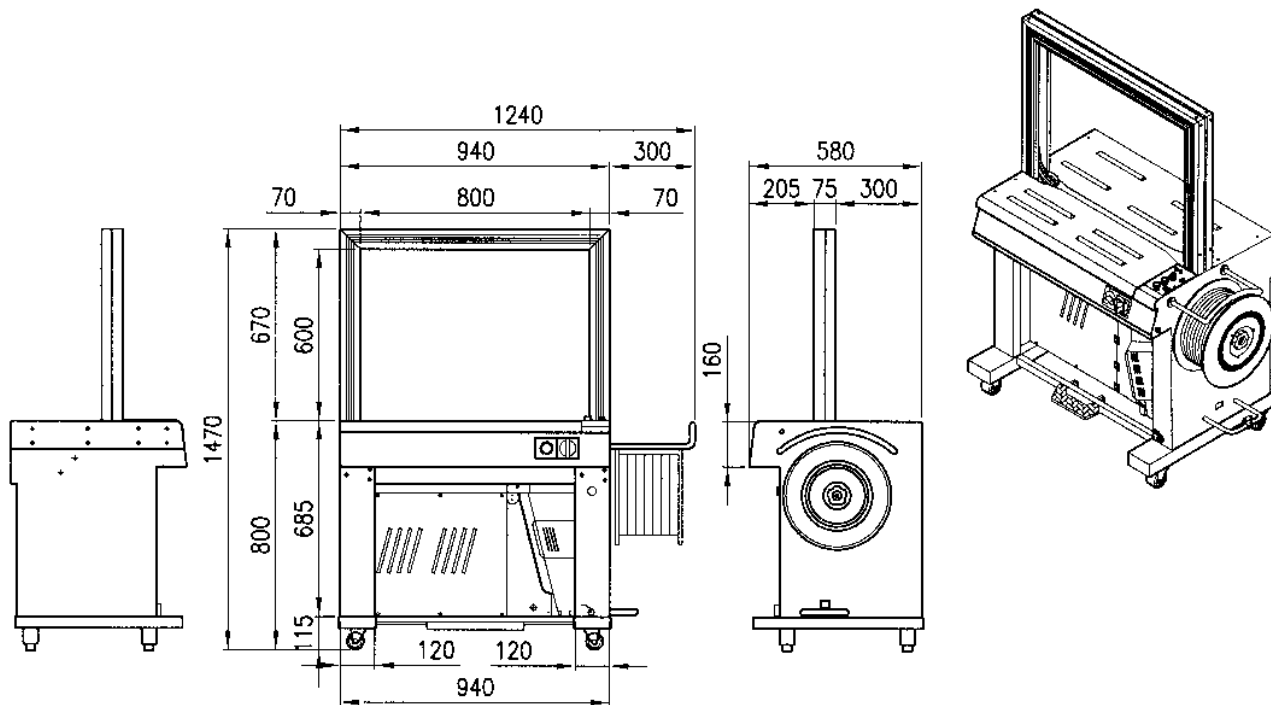

### Features:

Machine Size	1240 (W) x 580 (D) x 1470 (H) mm
Arch Size	800W x 600H mm (Standard)
Strap Cycle Speed	30 straps / Min. (50/60HZ)
Voltage	110V/220V/1 Phase, 220V/380V/415V/ 3 Phase
Tension Strength	10-75 KG
Strap Width	6-15 mm (Change Kits and Adjustment)
Packing Size	100-750 mm (Width), 30-575 mm (Height) (When packing width is smaller than 100 mm or packing height is smaller than 30 mm, mechanical design will be re-made accordingly.)

## ARCH INSTALLATION

Installing arch must follow the direction and securely tighten the screws with Strap Bandways. Please refer to the pictures below.

### WARNING !!

If the installation of arch is in the wrong direction, it will result in the breakdown of the machine and causing the damage of the arch flap and spring.

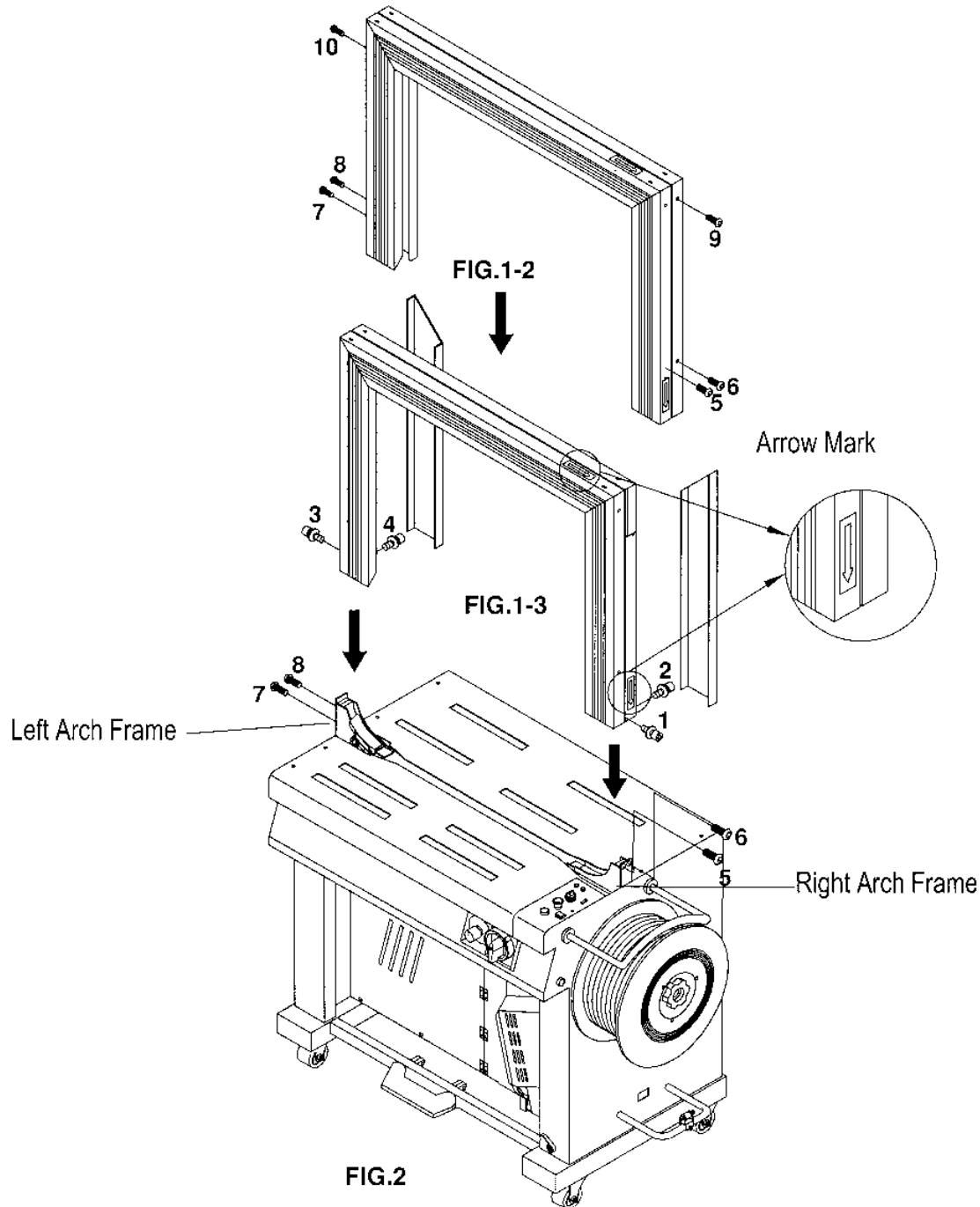

# MAJOR COMPONENTS AND STRUCTURES

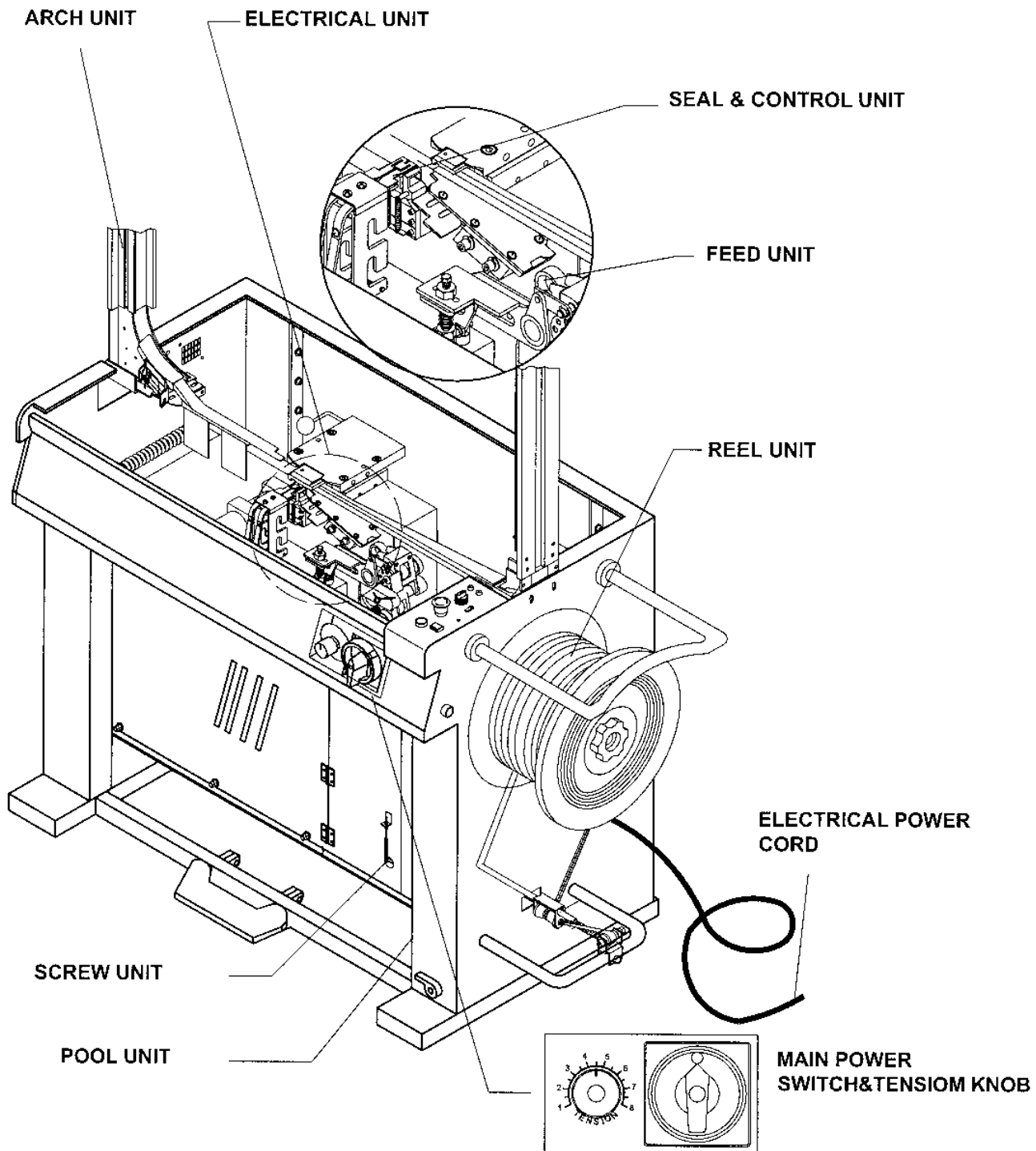

FIG.3 MAJOR COMPONENTS & STRUTURES

# STRAP THREADING PROCEDURE

## CAUTION !!

Please keep the Power Switch on including the Emergency Switch while threading or re-threading straps because it features an auto-feeding function.

**NOTICE 1:** Threading P.P. strap will fail if you don't turn on both switches. It will let strap stay in the pool box not reach the arch unit.

**NOTICE 2:** If the procedure of threading fails, you have to roll the spool anti-clockwise by a manual operation to draw back straps and repeat the procedure based on instructions

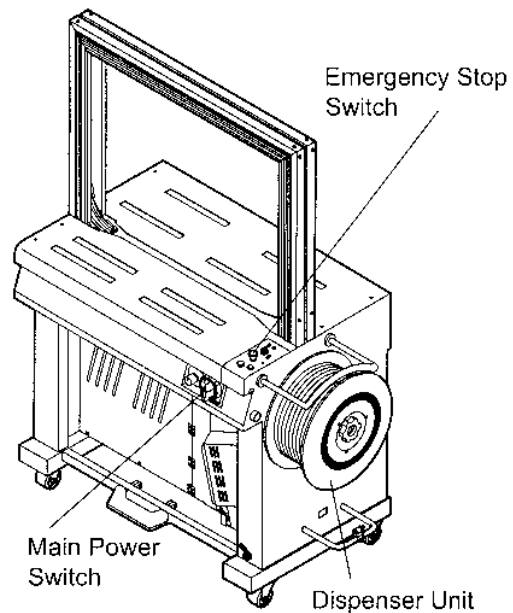

FIG.4-1

## SETTING STRAP 1

Remove the packing paper and string (5) on P. P. straps (1). And install it onto the dispenser according to the direction of arrow shows on the outer disc (4). Then, tighten the locking knob (2) against the coil after cutting strings if any on the P.P. strap coil.

Description:

- (1) P. P. Strap
- (2) Locking Knob
- (3) Upper Reel Guard
- (4) Outer Reel Flange
- (5) Packing String

## SETTING STRAP 2

Pull a sufficient length of P. P. Strap from the coil and thread it through the brake roller (6). Twist the strap 90 degrees clockwise and continue to thread the strap through the guiding roller (7) and then the pool box entrance (8) for 100 mm inside.

Description:

- (6) Brake Roller
- (7) Guiding Roller
- (8) Pool Box Entrance

**NOTICE:** Wrong twisting direction will cause the problem of positioning and fail the strapping.

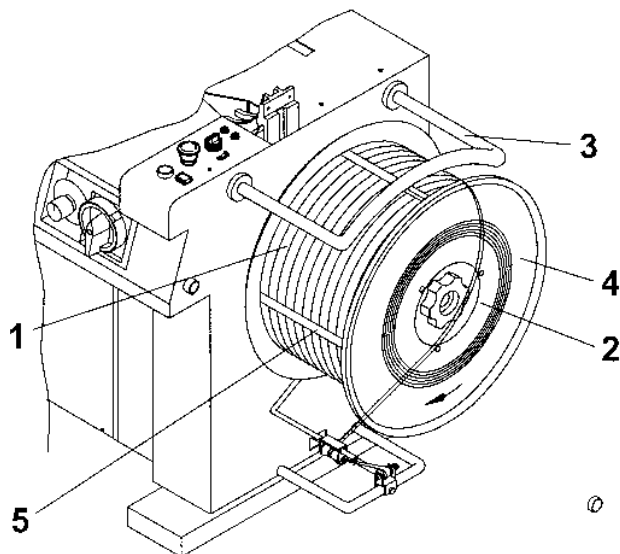

FIG.4-2

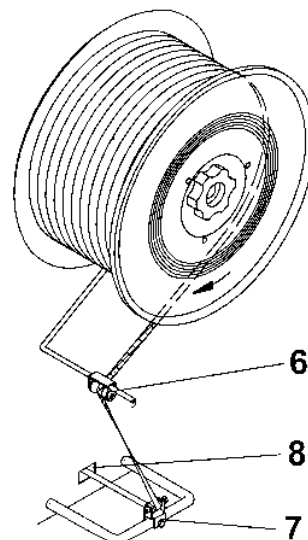

FIG.4-3

### SETTING STRAP 3

Turn on both the Main Power and Emergency switches. Then press the Feed Roller Lever (1) and insert the strap tip into the Pool Box Entrance (2) about 100 mm when you see the strap channel (3) is against the front panel of the pool box.

Description:

- (1) Feed Roller Lever
- (2) Pool Box Entrance
- (3) Strap Channel

### SETTING STRAP 4

Push the green "Insert Button" to start the auto-feeding function. When the proximity lamp turns "green" that means the strapping function is ready.

**NOTICE 1:** Please refer to the "AUTO-FEEDING INSTRUCTION" label stuck on the front view of machines.

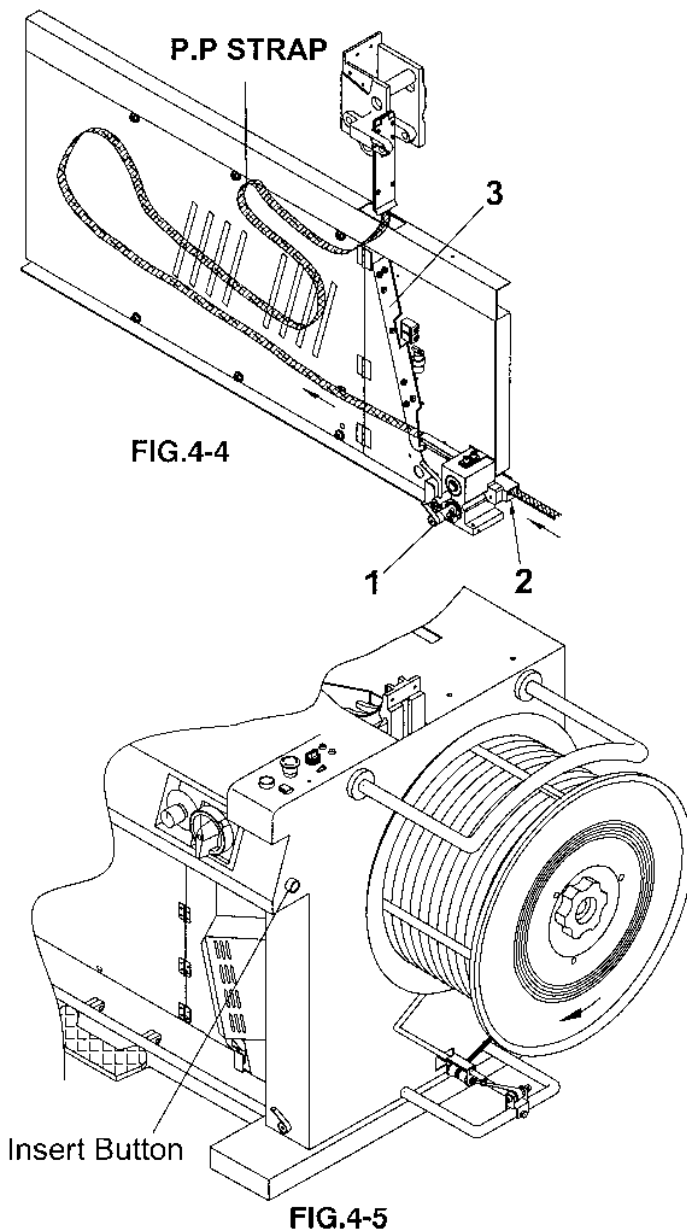

SETTING STRAP PROCEDURE
1. Turn on the Power Switch.
2. Thread the strap through the Roller(Fig-A) and then thread Guiding Roller(Fig-B).
3. Push the Knob(Fig-C) make Rail(Fig-D) closed and thread the strap into the Insertion Gap (Fig-E) about 100mm.
4. Push the Insert Button(Fig-F) when the green proximity lamp lights up, the strapping function is standby.

Fig.D  
Fig.F  
Fig.A  
Fig.C  
Fig.E  
Fig.B

## CONTROL PANEL

### (1) MAIN POWER SWITCH

This is the main power switch on the machine. Electrical power supply to the machine from the power source is controlled through this switch.

### (2) TENSION KNOB

Turn this knob clockwise to increase strapping tension; turn counter clockwise to decrease the strapping tension. (Refer Page 7)

### (3) RED LAMP

When the red-lamp lights up, it means strap is not fed properly or there are no sufficient straps in the arch unit (machine).

P.S. When there are no sufficient straps in machine, the red-lamp will blink, please push the Emergency Stop Switch and take out of the strap. Then, please follow the "Strap Threading Procedures" again. (Refer Page 4)

**NOTE: If you do not take out of the strap according to the above procedure, any function of the control panel fails.**

(4) **GREEN LAMP:** When the green-lamp lights up, it means this machine is standby for strapping.

### (5) FORWARDING & REVERSING SWITCH

Turn left to get the function of forwarding the strap. Turn right to get the function of reversing the strap.

### (6) EMERGENCY STOP SWITCH

The Stop Switch immediately shuts down the system and can be used as an Emergency Switch.

(7) **START BUTTON:** Push this button to do strapping.

Note: Turn on the Main Power Switch once, the start switch blinks for 25 Sec. to pre-heat.

### (8) RESET BUTTON

When the strap does not go to its' proper position or the strap is not sufficient, this switch will blink.

Please push this button to cut P. P. strap and take out of the strap from the Left Band way and push start button again. Then strap will go to its' proper position.

Note: If there is no any strap in Arch Unit, push this reset button to let this machine to its' home position.

### (9) SELECTOR ( for BALL SWITCH , START SWITCH & FOOT PEDAL SWITCH

Press this selector to get the functions of Ball Switch, Start Switch and Foot Pedal Switch.

### (10) INSERT BUTTON

When a strap tip is threaded into the pool box entrance, push this button to start the Auto-Feeding function.

It takes about 7 Sec. to complete the Auto-Feeding Procedure.

### (11) FOOT PEDAL SWITCH

Please press the selector to "FOOT" to get the function of Foot Pedal Switch

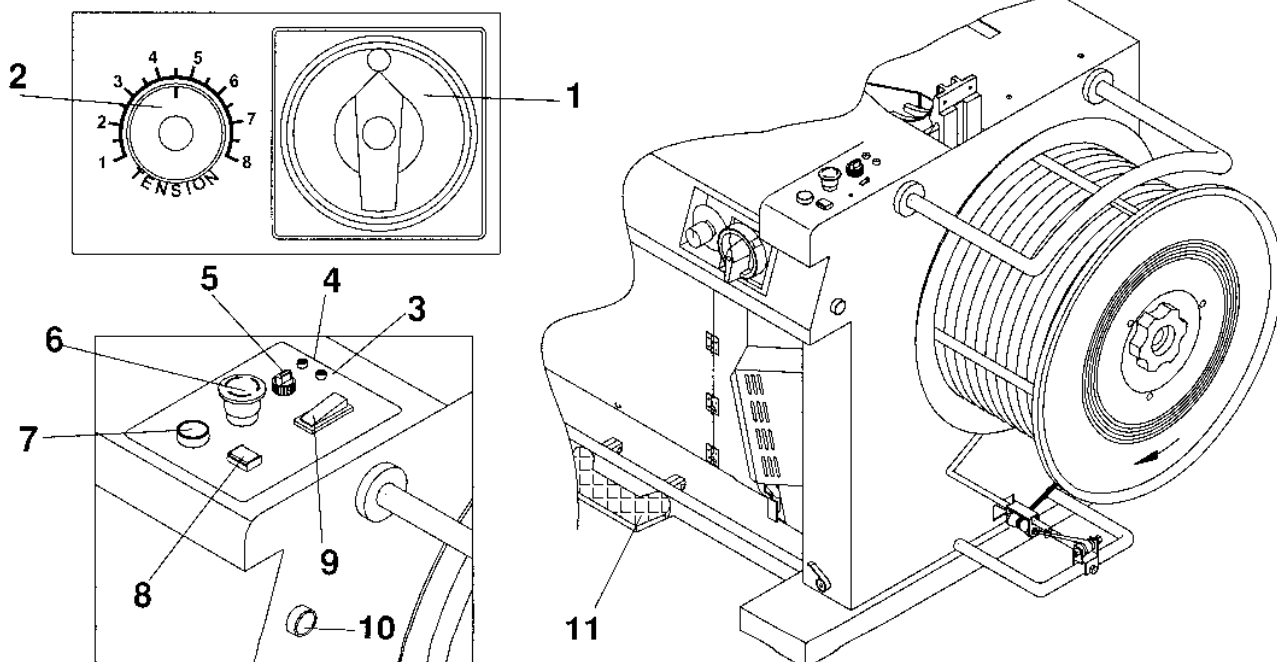

FIG.6



## TENSION ADJUSTMENT

Turn this knob clockwise to increase strapping tension; turn counter clockwise to decrease the strapping tension. Normally, the standard tension is set up before shipment. You can do the Internal Tension Setting by yourselves. (Refer to Page 14). Basically, the internal Tension is set up on "2".

### NOTE!!

- (1) Please set up the proper tension in accordance with the package size and material. If the package size is small or soft, please dial "2". You can check and adjust the tension by yourselves.
- (2) If the package is wooden cases or plastic cases, DO NOT set up the tension in "5" directly. Suppose the quality of P. P. strap is not good enough or tension setting is over "5", the strap will be broken.
- (3) The above unusual situation will make some feeding & reversing problems. Please remove and assemble the strap guide assembly accordingly. (Refer to Page 11)The purpose is to take out of the strap left in the front & back strap guide assembly.

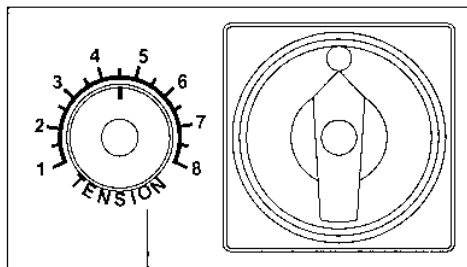

TENSION  
KNOB

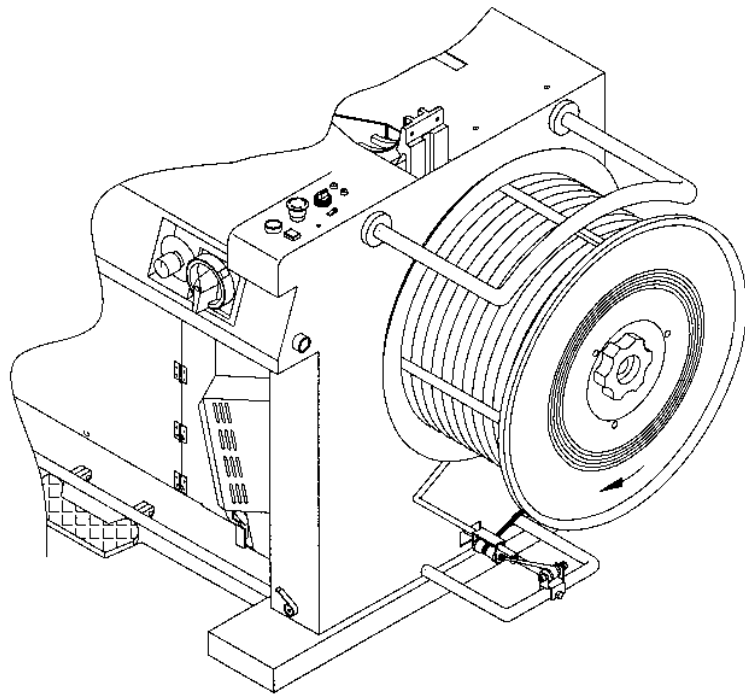
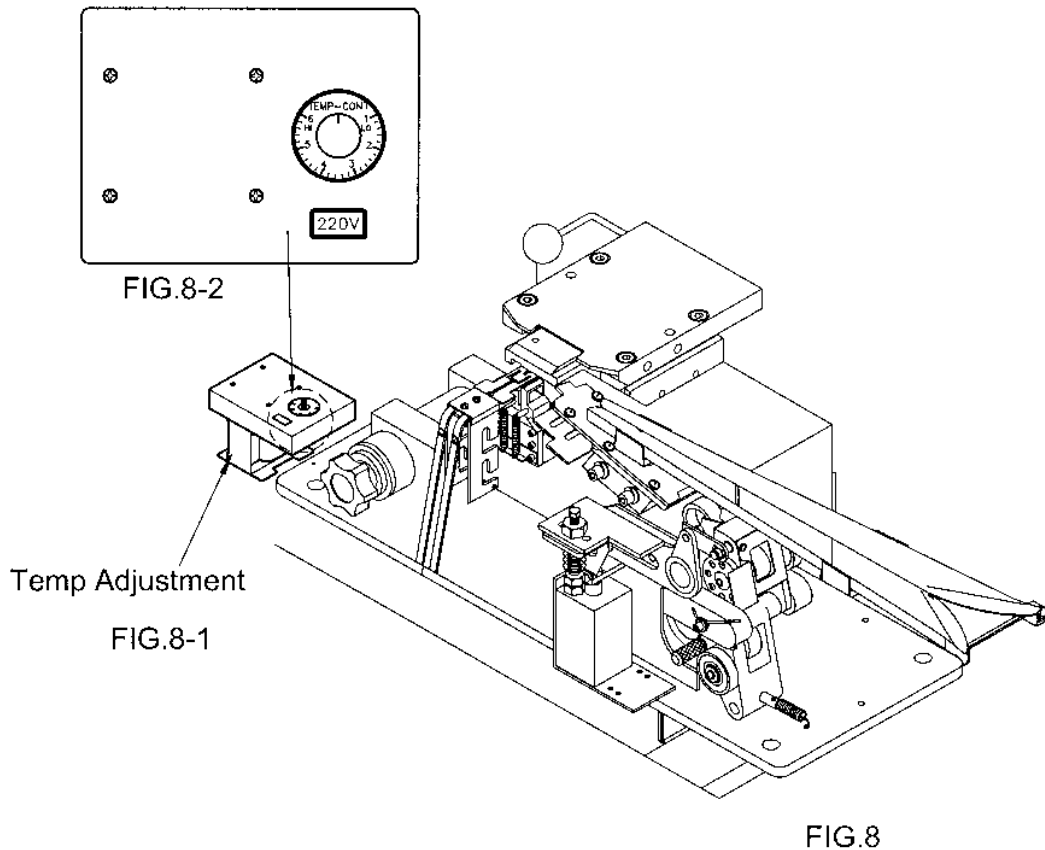

FIG.7

## TEMPERATURE ADJUSTMENT

The temperature is set up in accordance with the material of P. P. strap before shipment. Normally, the standard temperature is set up at "3". (Refer to Page 8) When the voltage is too high or too low, you have to do some adjustment. If you change the specification of P. P. strap, you have to make some adjustment accordingly. Standard setting is as follows :

- (1) Turn on the Main Power Switch to pre-heat (about 25 Sec.) automatically. When the Start Switch lights up, you can do your strapping.
- (2) You have to adjust the temperature in accordance with the real sealing status of strap. If the surface of the sealing area of strap is too wet, you have to adjust the knob to higher temperature. On the contrary, you have to adjust the knob to lower temperature if it looks too dry.



## POOL BOX P. P. STRAP ADJUSTMENT

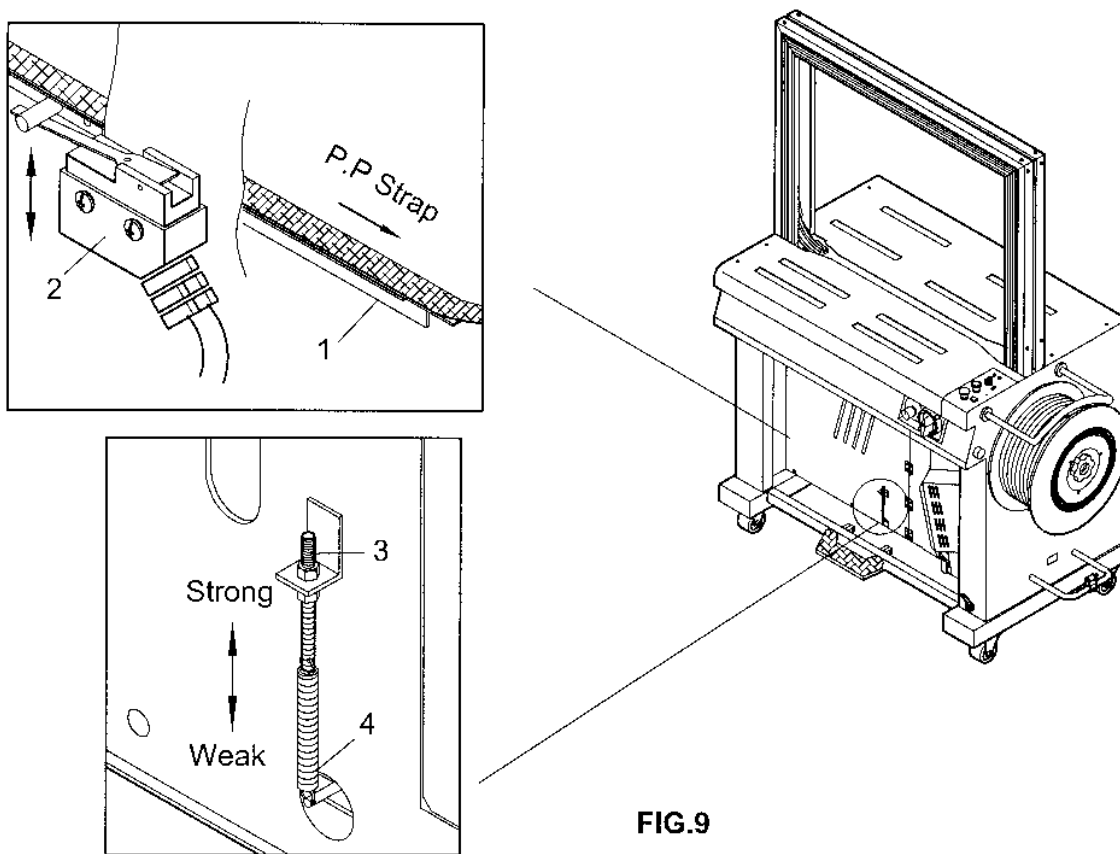

FIG.9

The original technical idea of this machine is to get a speedy feeding system. Before or during strapping work, the strap will be stored into the pool box in accordance with the real strapping status. If the weight of the strap in the Pool Box is too light, the Micro switch (2) will not be activated and the pool box motor will keep feeding strap. On the contrary, if the weight of the strap in the Pool Box is just right, the Micro switch will be activated and the pool box motor will stop running and feeding strap.

### ADJUSTMENT

Please release the screw nut (3) by wrenches and adjust the spring (4) vertically up forward for storing more straps and down forward for less straps in the pool box.

### CAUTION!!

- (1) If the strap is insufficient, it will cause the failure of strapping and reversing of straps due to an improper positioning of straps.
- (2) If the strap is too much in the pool box, the strap will be curved by this situation. It will cause the strap is not available to go to its' proper position, either.
- (3) If you need to change different specifications (width and thickness) and quality of strap, you have to do Pool Box P. P. Strap Adjustment again.
- (4) Normally, the strap will be stored into the pool box every 2 straps.

## FORWARDING & REVERSING ROLLERS GAP ADJUSTMENT

When you use different thickness of strap in this machine, it will cause different pressure of forwarding & reversing of strap. Please refer to the following procedures to adjust it.(Refer Fig. 10)

### FORWARDING & REVERSING SOLENOID ADJUSTMENT

- (1) Please make sure there is no any strap in the machine and press the check point (A) tightly. The purpose is to make sure there is no any gap between the roller (a) and roller (b).
- (2) Please adjust the height of Solenoid and make sure there is only 1 mm gap between the top of the Solenoid (B) and E ring of the core of Solenoid. Then, fix the solenoid.

### FORWARDING & REVERSING ROLLERS GAP ADJUSTMENT

- (1) Please prepare 2 straps (length about 30 cm) to pile together (total thickness =thickness of 2 straps) to check the gap of machine. Please insert these 2 straps together from (C) via (a) & (b).
- (2) Please press (A) and adjust the (D) to contact the E ring. Then, fix the (D).
- (3) When the forwarding pressure of strap is too high, please loosen the nut (E) and adjust the screw clockwise. Then, fix the screw again.
- (4) When the forwarding pressure of strap is too low, please loosen the nut (E) and adjust the screw counter-clockwise. Then, fix the screw again.

### CAUTION !!

As to Spring (F), please do not change to any other specification. Because this specified spring will influence the operation of feeding and reversing.

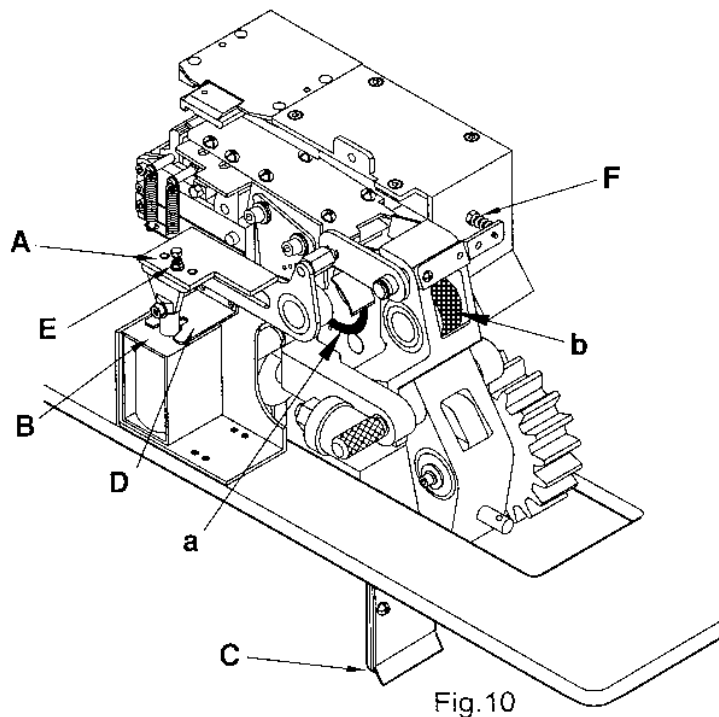

## REMOVING & ASSEMBLING OF STRAP GUIDE ASSEMBLY

When a piece of P. P. strap left in the front & back strap guide assembly which can cause obstruction. Please try to remove & assemble the strap guide assembly accordingly. (Refer Fig.11-1 and Fig. 11-2)

### HOW TO REMOVE?

Refer to Fig.11-1, to remove the pin (a) by a pair of pliers and lift Roller Tension Plate (b) and open Back Strap Guide Assembly to right side. And take litter away.

It might be not to see any obstruction in Back Strap Guide Assembly after opening. Follow the procedured (Fig.11-2) to remove pin (c), tension pin and check if there is any litter in Front Strap Guide assembly.

### HOW TO INSTALL?

Refer to above steps and install counter side.

### CAUTION!!

In order to keep all construction completely, besides the above mentioned parts, do not change any other parts.

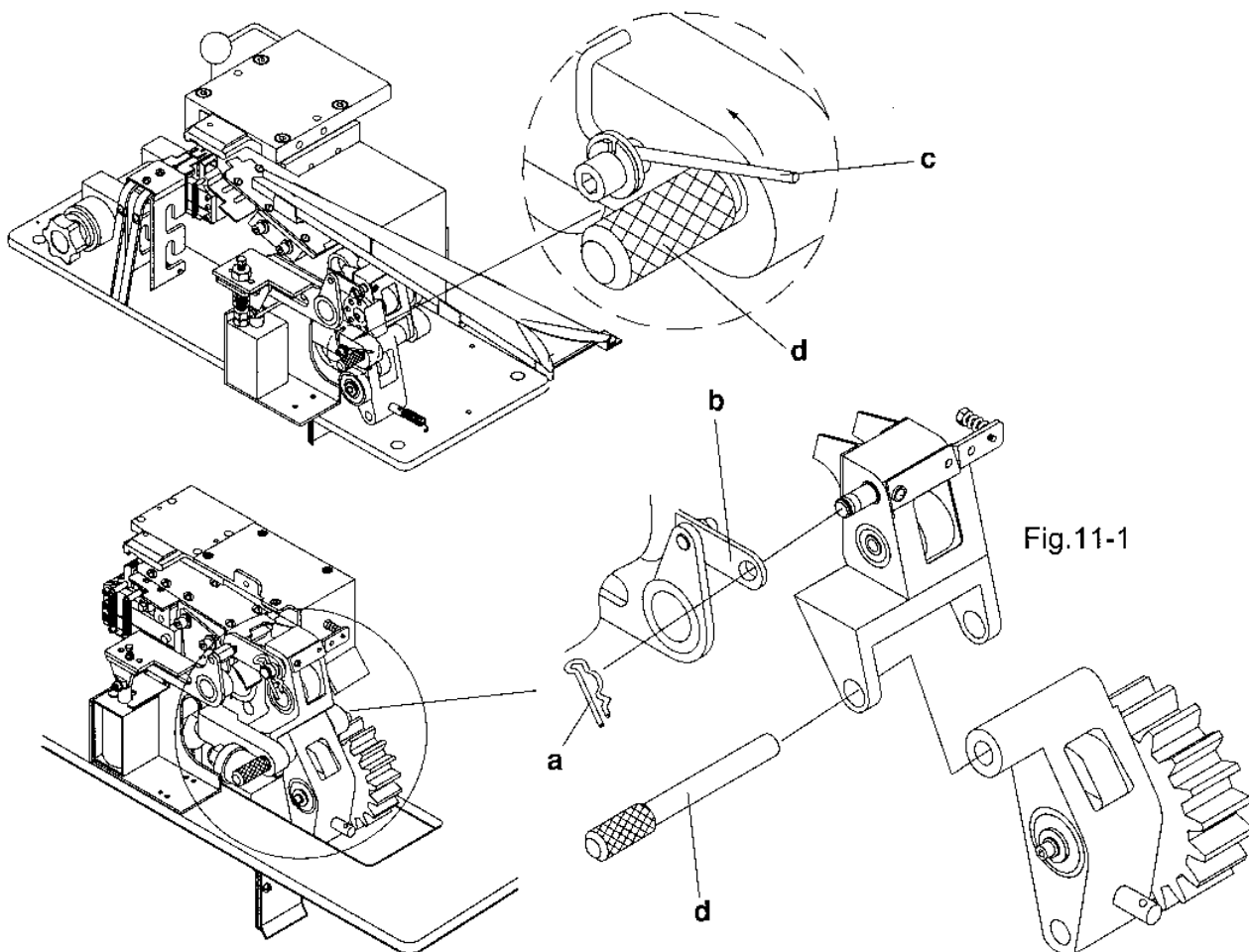

Fig.11-1

Fig.11-2

## PROPER P. P. STRAP ALIGNMENT

Please do as following steps to adjust the alignment of the P. P. strap when it is not connected uniformly (Refer to the drawing below).

### CONDITION A:

STEP 1: Loosen the Hex. Screw & Nut of Right Bandway NO.1, 2, 3, 4 and move the Right Bandway to right side till the strap is sealed uniformly.

STEP 2: Tighten the Hex. Screw & Nut NO.1, 2, 3, 4.

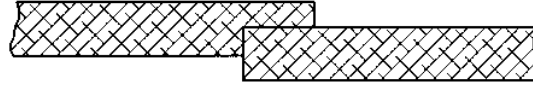

### CONDITION B:

STEP 1: Loosen the Hex. Screw & Nut of Right Bandway NO.1, 2, 3, 4 and move the Right Bandway to left side till the strap is sealed uniformly.

STEP 2: Tighten the Hex. Screw & Nut NO.1, 2, 3, 4.

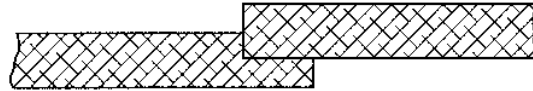

### CAUTION!!

Do not loosen the Fixed Screw & Nut No. 5 of Right Bandway.

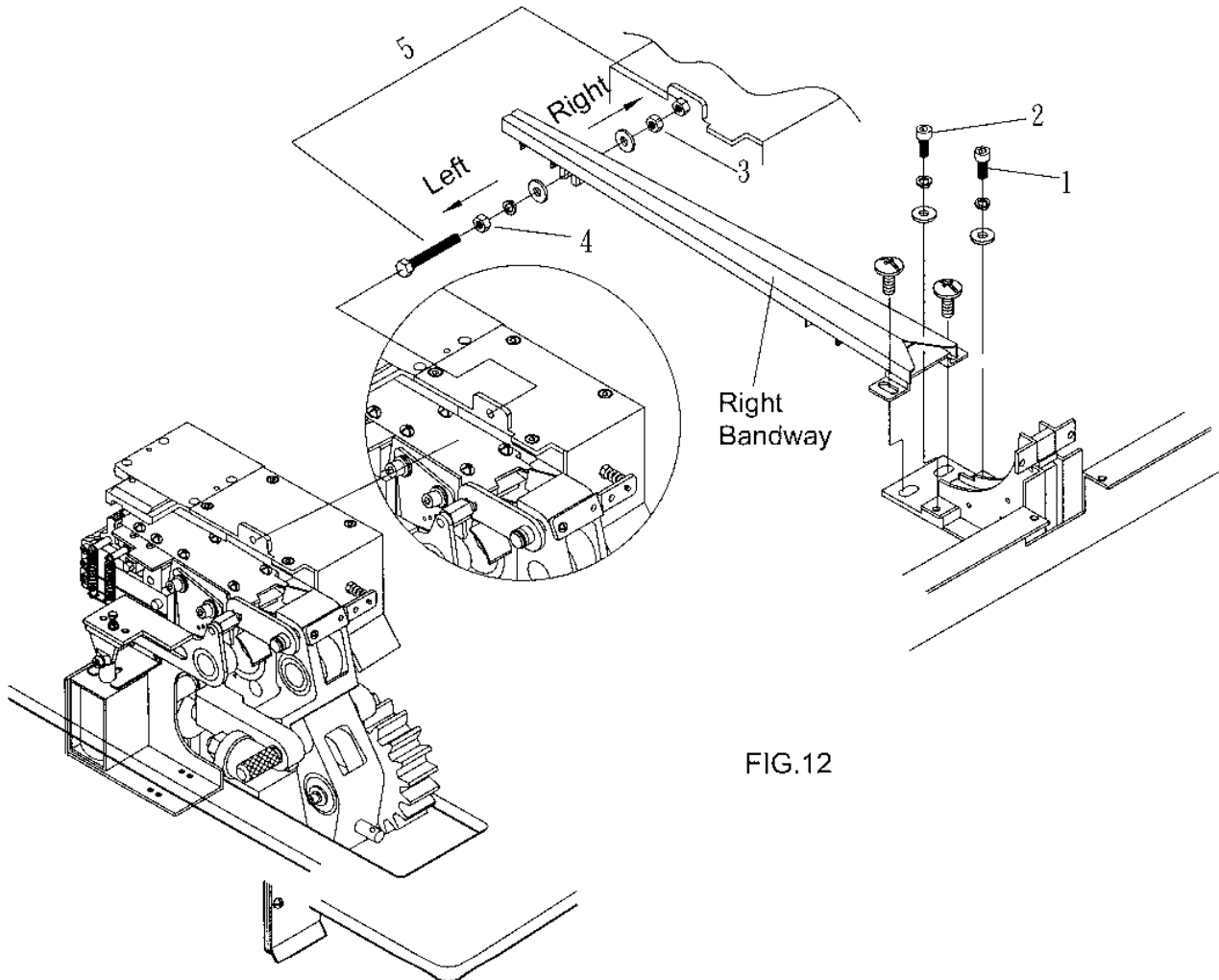

FIG.12

## CONTROL BOX

### (1) TRANSFORMER

The AC-16V power supply will be transferred via this transformer (Refer FIG. 13, No. 1).  
The power supply will be used by the Main P. C. Board (Refer FIG. 13, No. 3) and SSR  
M1 Motor and M2 Motor Control Unit (Refer FIG. 13, No. 2).

### (2) SSR (Solid State Relay) M1 Motor and M2 Motor Control Unit

The main function of Solid State Relay is to control M1 Motor and M2 Motor.  
(Refer FIG. 13, No. 2)

### (3) MAIN P. C. BOARD

Except M1 & M2 motors, all of the functions of machine are controlled by this Main P. C.  
Board. (Refer FIG. 13, No. 3)

### (4) FUSE SET

The main function of these 2 pieces of fuse (Refer FIG. 13, No. 4) is to protect the  
SSR M1 & M2 Motors Control Unit. (Refer FIG. 13, No. 2)

Specification: 110 / 115V~8A  
220 / 240V~10A

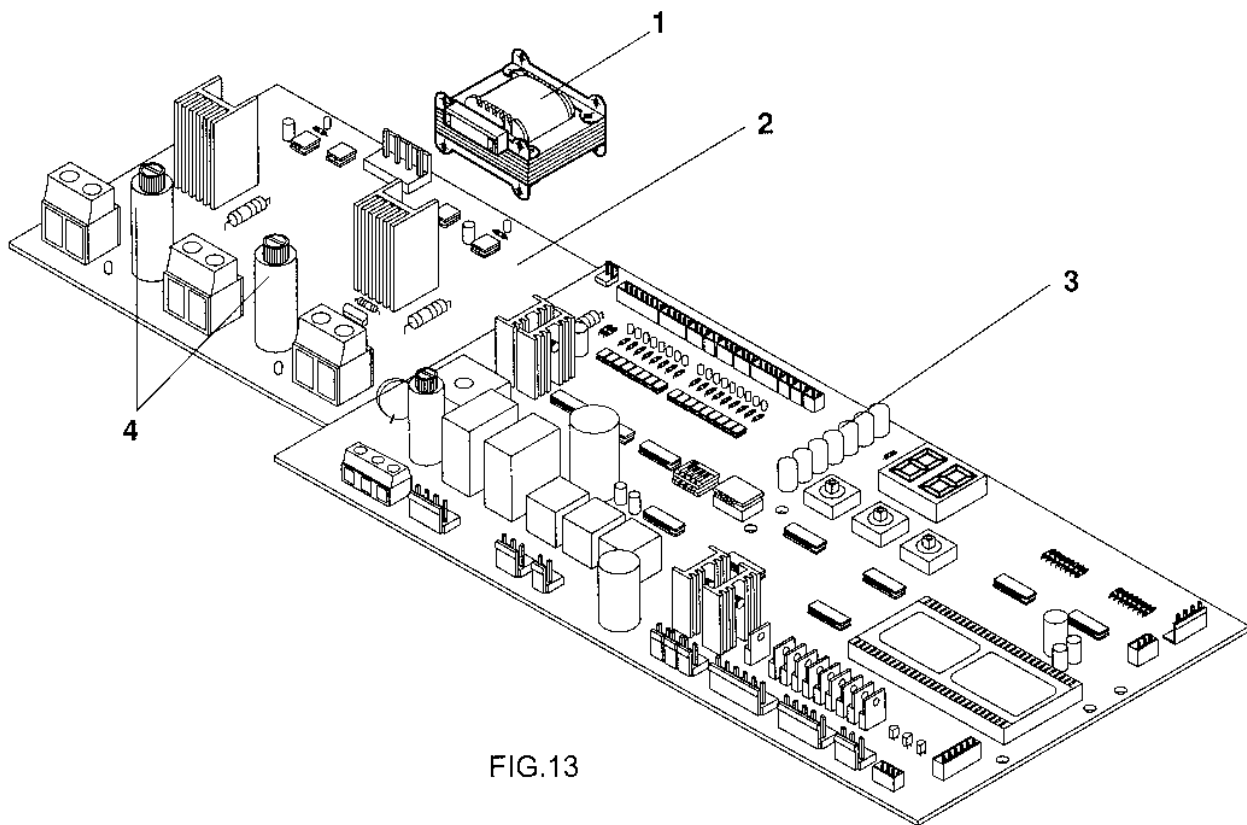
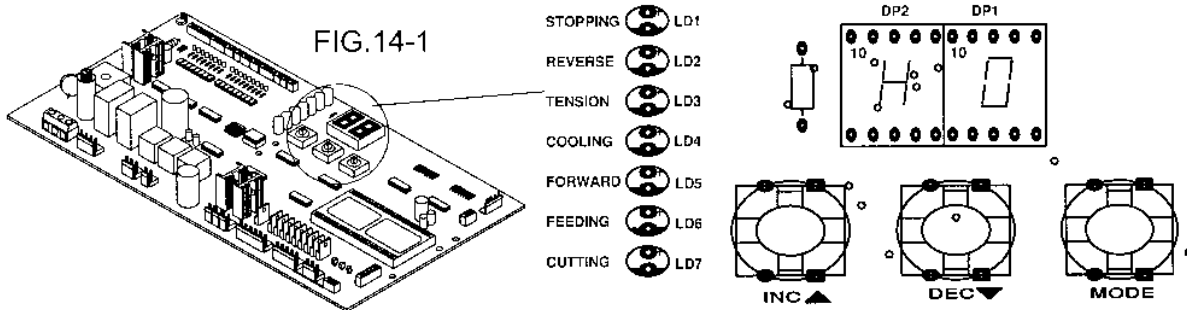

FIG.13

# M60AX TIME SETTING & ADJUSTMENT

## TIME SETTING PROCEDURES

1. Push "Emergency Stop" switch and LD1~LD7 will blink. The LED display will come out "HO". Awaiting for next setting.



## 2. SETTING PROCEDURE

- 2-1 Push "Mode" for 3 seconds, and the LD1 (STOPPING) lights up and push "INC (+)" or "DEC (-)" to adjust time. Then, push "Mode" once again to adjust next function. (This way is only suitable to set LD1~LD6).
- 2-2 If you need to set up the cutting time (LD7), please poke Set Switch (Refer FIG.14-2) No.2 to "ON". Then, push "Mode" for seven times, you can try to set the cutting

## 3. STANDARD SETTING OF MACHINE

- LD1 STOPPING TIME
- LD2 REVERSE TIME
- LD3 TENSION TIME
- LD4 COOLING TIME
- LD5 FORWARD TIME
- LD6 FEEDING TIME
- LD7 CUTTING TIME

### STANDARD SETTING

2	0	→ 20sec.
2	7	→ 0.54sec.
0	2	→ Second Section
0	2	→ 0.2sec.
1	0	→ 1.0sec.
2	0	→ 2.0sec.
4	5	→ 0.45sec.

## 4. SET SWITCH SETTING

- 4-1 Poke the switch No.1 to "ON" to cancel the function of "REVERSE SENSOR". (Refer to FIG. 14-2)

※ This function is only suitable for the situation of breaking down of reverse sensor.  
 Note: The machine is still working normally.

- 4-2 Poke Switch No.2 to "ON" to set up the cutting time. After setting, please return to "RESET".

- 4-3 Poke Switch No.3 to "ON" to set up the time of Mini. Package. After setting, please return to "RESET"

- 4-4 Poke Switch No.4 to "ON" to cancel "DOUBLE TRY" function

※ Normally, Double Try Function is canceled for big size arch. (Over 1000mm compare to standard size of arch)  
 However, it can not be cancelled, either.

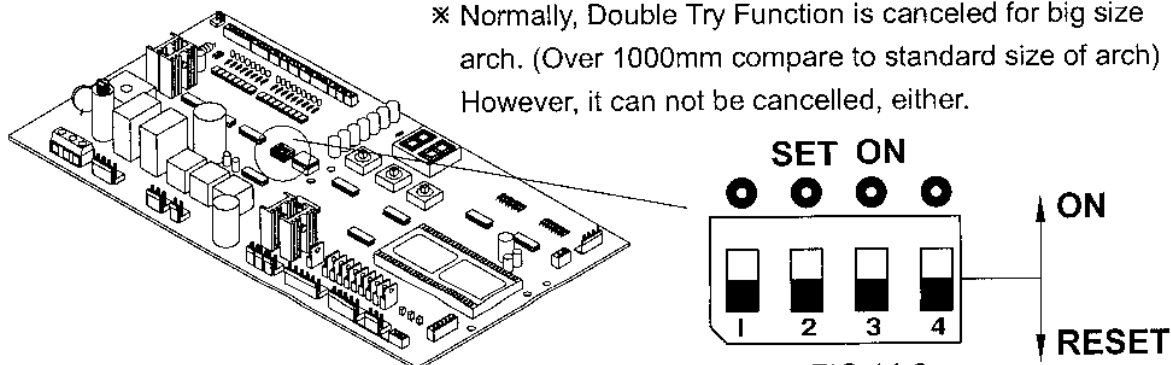

FIG.14-2



# M60AX SIGNAL INDICATION

The PC board will automatically inspect itself by showing the signals on the LED display. Each signal indicates the possible problems and where it happens. Please refer to the information as follows.

- E2 : REVERSE CLUTCH
- E3 : TIMING BRAKE
- E4 : TENSION CLUTCH
- E5 : TIMING CLUTCH
- E6 : FORWARD & REVERSE SOLENOID
- E7 : FEED CLUTCH
- E8 : POOL CLUTCH
- E9 : NO STRAP IN THE POOL BOX

These signals also show the possible problems happening on the transistor.

- E1 : 40 TRANSISTOR
- E2 : 27 TRANSISTOR
- E3 : 23 TRANSISTOR
- E4 : 18 TRANSISTOR
- E5 : 29 TRANSISTOR
- E6 : 14 TRANSISTOR
- E7 : 25 TRANSISTOR
- E8 : 41 TRANSISTOR

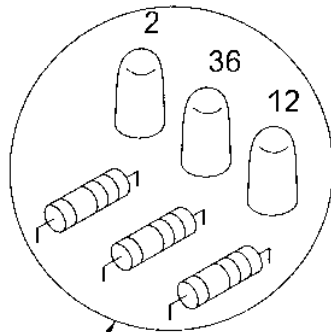

\*\* WHILE LED IS BROKEN, PLEASE MODIFY SERIES CONNECTION TO PARALLE CONNECTION . BETWEEN LED AND RESISTANCE, WHICH MAKE ELECTRIC CURRENT PASS SMOOTHLY AND REVERSE AGAIN.

FIG.14-1

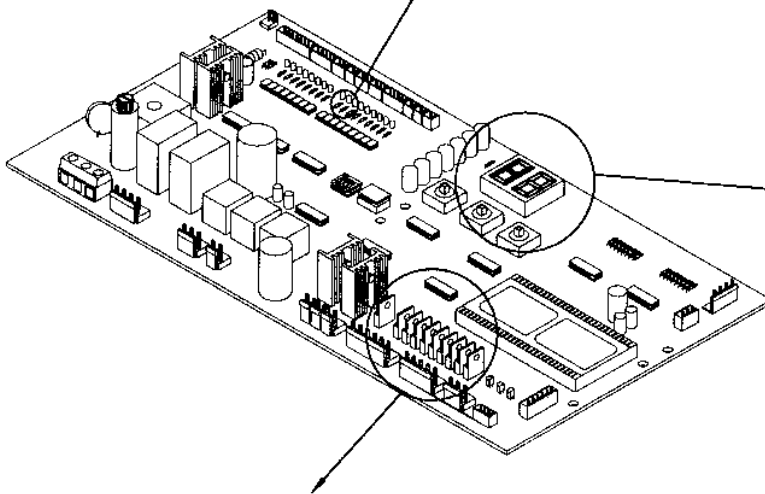

- E1
- E2
- E3
- E4
- E5
- E6
- E7
- E8
- E9

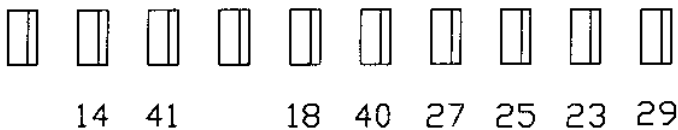

## TIMING ADJUSTMENT

The reaction of machine is controlled by proximity switches (LS-1, LS-2 & LS3) and contact of cam. Please refer to instruction and do adjustment below.

### CAUTION!!

Turn off the power before adjusting the proximity switches. Only well trained technician is permitted to do the adjustments. Any inappropriate adjustments can affect operation of machine and result in personnel injury.

### NEUTRAL & FORWARD FEEDING POINT

1-1 The neutral position, feeding point LS-1 (Fig. A) and LS-1 Cam are inducing each other. When lamp of LS-1 is lighting, please check the position of tension cam (Refer to parts no.M01001B) and cam follower (Refer to Fig. A-A). If it is not in right position, please check and adjust the knob of gear box by hand (Refer to Fig-15) and to set the position (Refer to Fig. A-A) and remove cam of LS-1 same as drawing Fig. A. In the meantime, turn on power switch and light is on which represents correct position.

**NOTE: LS-1 and point of cam LS-1 should be inducing each other in  $1.0 \pm 0.2\text{mm}$ .**

- 1-2 When in neutral position, the top sliding plate will move to front point of the sealing head.
- 1-3 The End Gripper at the lowest point.

### REVERSE FEEDING POINT

- 2-1 When cam is leaving LS1 and lamp of LS1 is off which represents machine starting to reverse.
- 2-2 The position between LS-1 and cam of LS-1 should follow Fig B-B.

**Remark: Any wrong position will affect to operation of machine, please refer to 1-1 to adjust.**

### TENSTION POINT

- 3-1 When cam of LS-2 is reaching LS-2 which represents machine start to tension.
- 3-2 The cam follower will be at the top point on the cam (Fig. C-C)

### COOLING TIME POINT

- 4-1 When set-plate is reaching LS-2 which represents machine starting to cool. In the mean time the plunger should on the top point.
- 4-2 Adjust proper cooling time is available by setting the set-screw of set-plate on the cam.
- 4-3 If the cooling time is not necessary, set-plate can be moved out.

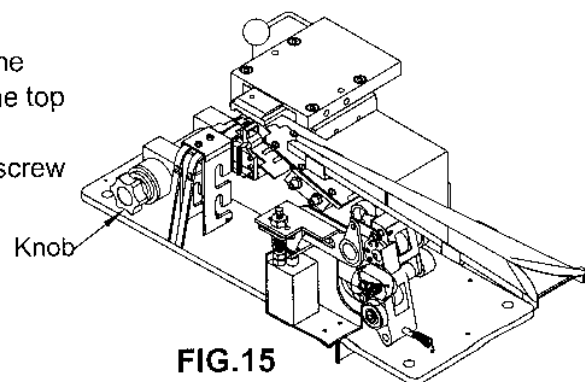
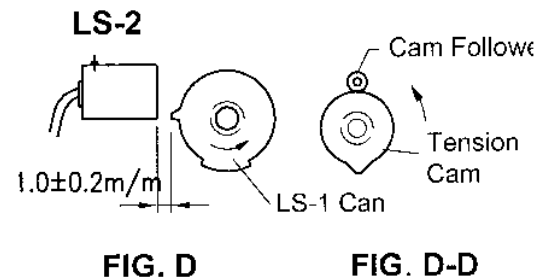
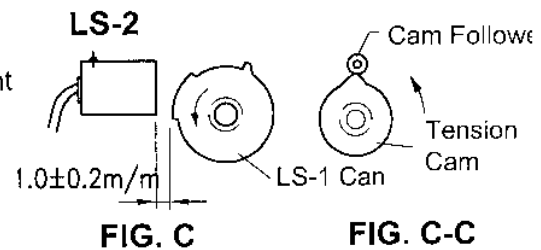
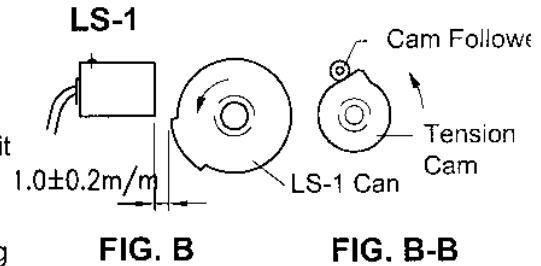
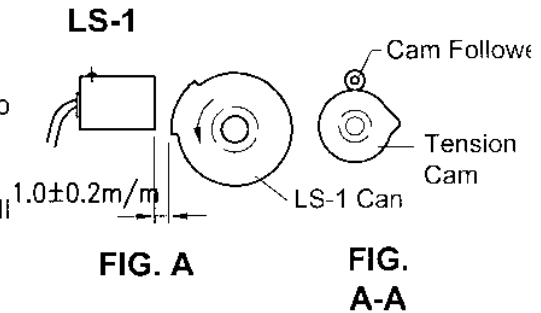

## SYMBOL OF ELECTRIC ACCESSORY OF DRIVE UNIT

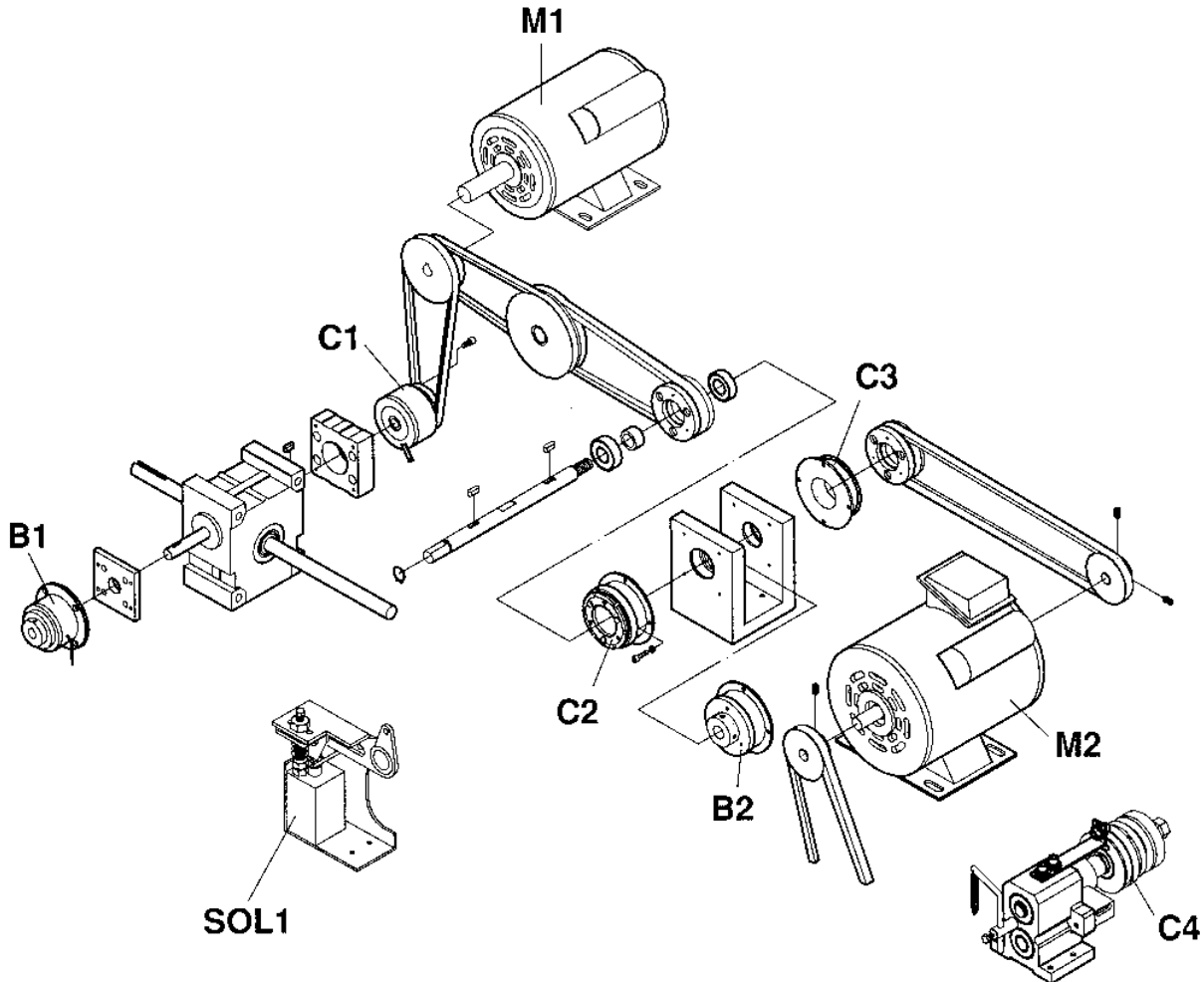

## SYMBOL LIST OF DRIVE UNIT

SYMBOL	DESCRIPTION
M1	Timing Motor 1/2HP Single Phase/ Three Phase
M2	Pool Motor 1/3HP Single Phase/Three Phase
SOL1	Auto-Feeding Solenoid
C1	Reducer Clutch 0.6K DC-24V
C2	Forward Feeding Clutch 0.6K DC-24V
C3	Reverse Feeding Clutch 0.6K DC-24V
C4	Pool Clutch 0.6K DC-24V
B1	Reducer Brake 0.6K DC-24V
B2	Forward & Reverse Feeding Brake 0.6K DC-24V

## CLEANING & MAINTENANCE

In normally operation, there is any cutting strap or dust of strap might be left in the machine. Please clean inside of the machine by brush or spray gun frequently. After cleaning, please apply some (2-3 drops) oil by referring to drawing.

**Remark: To lubricate once a month.**

### CAUTION !!

Never lubricate the feed rollers, tension rollers, belts and clutches. If oil attaches to these parts, tight and proper fastening cannot be made due to slipping and the drive units, belts or clutches will not move normally too.

Particularly be careful not to put oil on the belt or the life will be remarkably shortened.

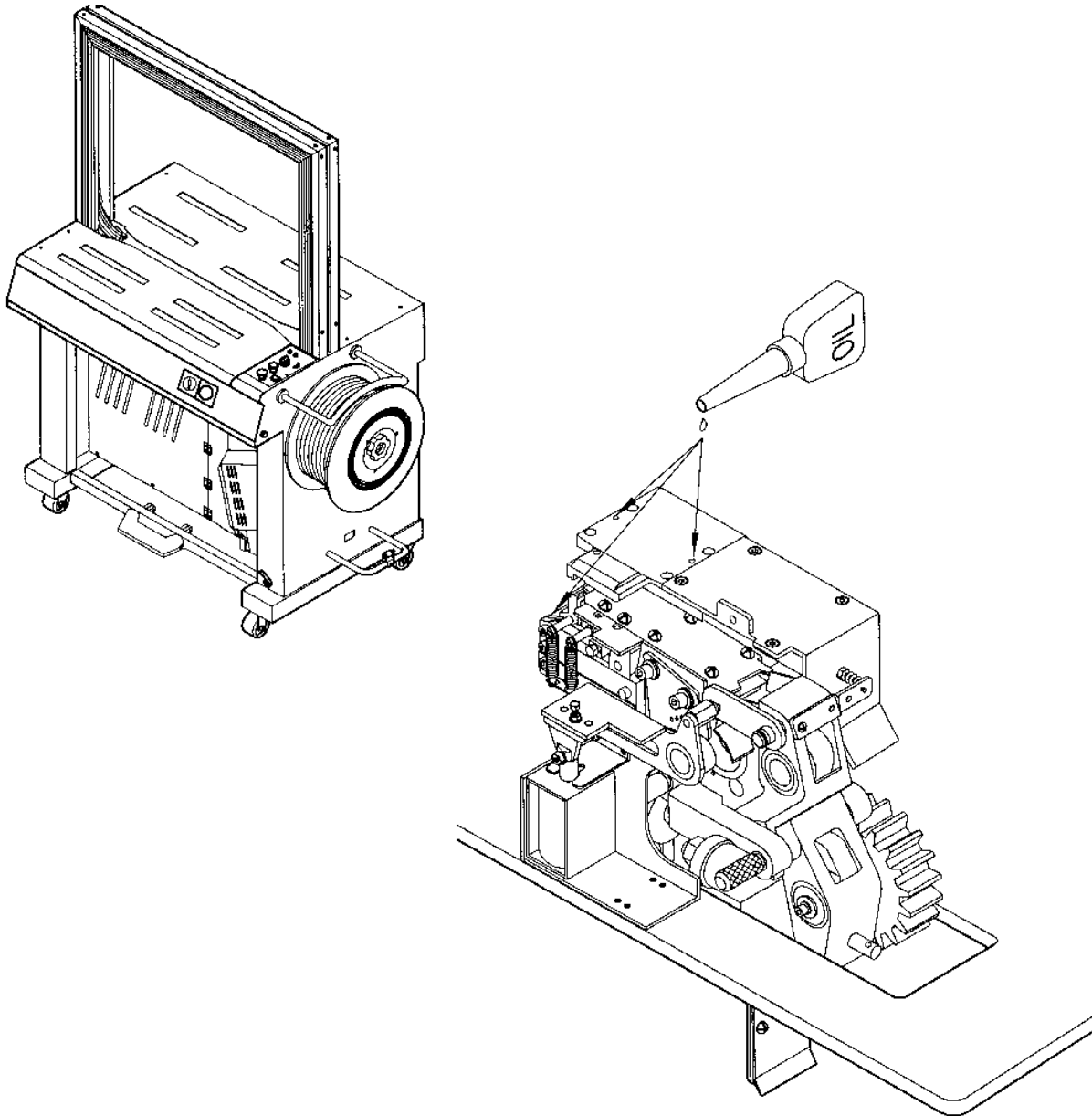

## EASY TROUBLE-SHOOTING GUIDE

### CONDITION 1: TROUBLE ON AUTO-FEEDING

**Reason (A):** Wrong direction of P. P. strap

**Solution** : Refer to page 4 setting strap (FIG. 4-1 & 4-2). Please re-check the direction of brake arm to insertion gap is correct or not?

**Reason (B):** Power Switch is "OFF"

**Solution** : Refer to page 5. This machine is equipped with Auto-Feeding system, please keep power to be supplied to this machine. When you put the strap through, please turn on the Main Power Switch & release the Emergency Stop Switch.

**CAUTION!!** When you do the first threading of strap or re-feeding of strap, It is an essential & very important procedure. Any wrong operation will cause the strap does not go into the arch unit properly.

**Reason (C):** No signal or break down of Auto-Feeding System

**Solution** : Refer to page 18 (FIG. 17-1), open the cover of Auto-Feeding system (Pool Box) and check wire No.15 and No.21 of terminal bracket. Please use meter to check the input Voltage (DC-24V)? Try Auto-feeding procedure again. If the power is supplied to SOL-2, it means that SOL-2 is burned or the strap guide is jammed or loose. If there is no input DC-24V, you have to check the main P.C. Board in control box (Refer to page 13 FIG.13).

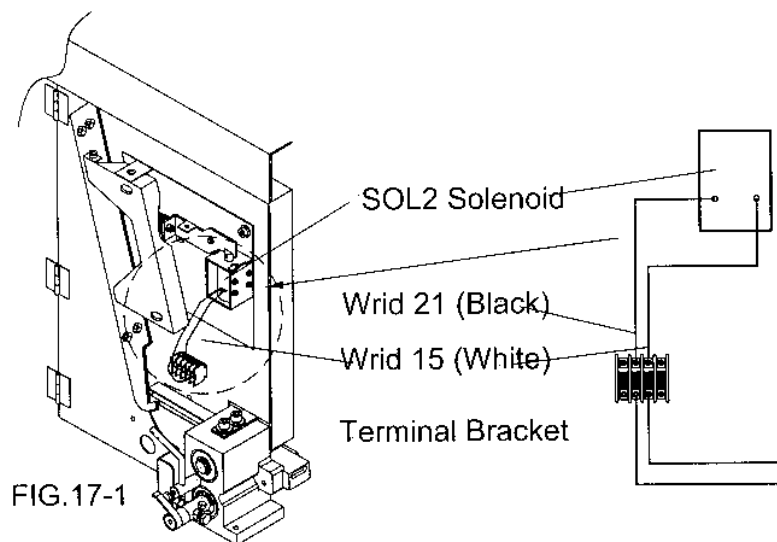

**Reason (D):** Insufficient of P. P. strap

**Solution** : Refer to page 5 (FIG. 4-4). PP strap should be inserted about 100mm and make roller move.

**Reason (E):** No reaction after inserting of P. P. strap

**Solution** : Refer to page 5 (Setting Procedure 4), you have to push INSERT BUTTION. After inserting the P. P. strap in 20 seconds, you have to re-confirm the Strap Threading Procedure again. (Refer to page 14, LD6 Auto-Feeding time is 20 sec.).

## **CONDITION 2: OBSTRUCTION OF STRAP GUIDE & FEEDING PROBLEM**

**Reason(A)**:Bad quality of P.P. strap or strap too tight. It will cause P.P. strap break.

**Solution(A)**:Refer to Page 11 remove Strap Guide Assembly and clear left strap.

**Reason(B)**:a piece of P.P. strap is left in the machine

**Solution(B)**:Refer to Page 6 Control Panel. As LED red light is blinking. It means P.P. strap is left in strap guide.

## **CONDITION 3:THE P.P. STRAP RUNS OUT OF ARCH**

**Reason(A)**:Feed spring is too strong or P.P. strap is too thick.

**Solution(A)**:Refer to Page 10.

**Reason(B)**:Wrong direction of P.P. strap, it causes P.P. strap run out from arch.

**Solution(B)**:Refer to Page 4 Strap Threading Procedure.

## **CONDITION 4:LOW TENSION OR HIGH TENSION**

**Reason(A)**:It might be occurred tension insufficient or over high tension when package or the specification of P.P. strap are different, please do Internal Tension Adjustment.

**Solution(A)**:Refer to page 14, LD3(Internal Tension Adjustment) to adjust to 01 or 03.

# ELECTRICAL SCHEMATIC

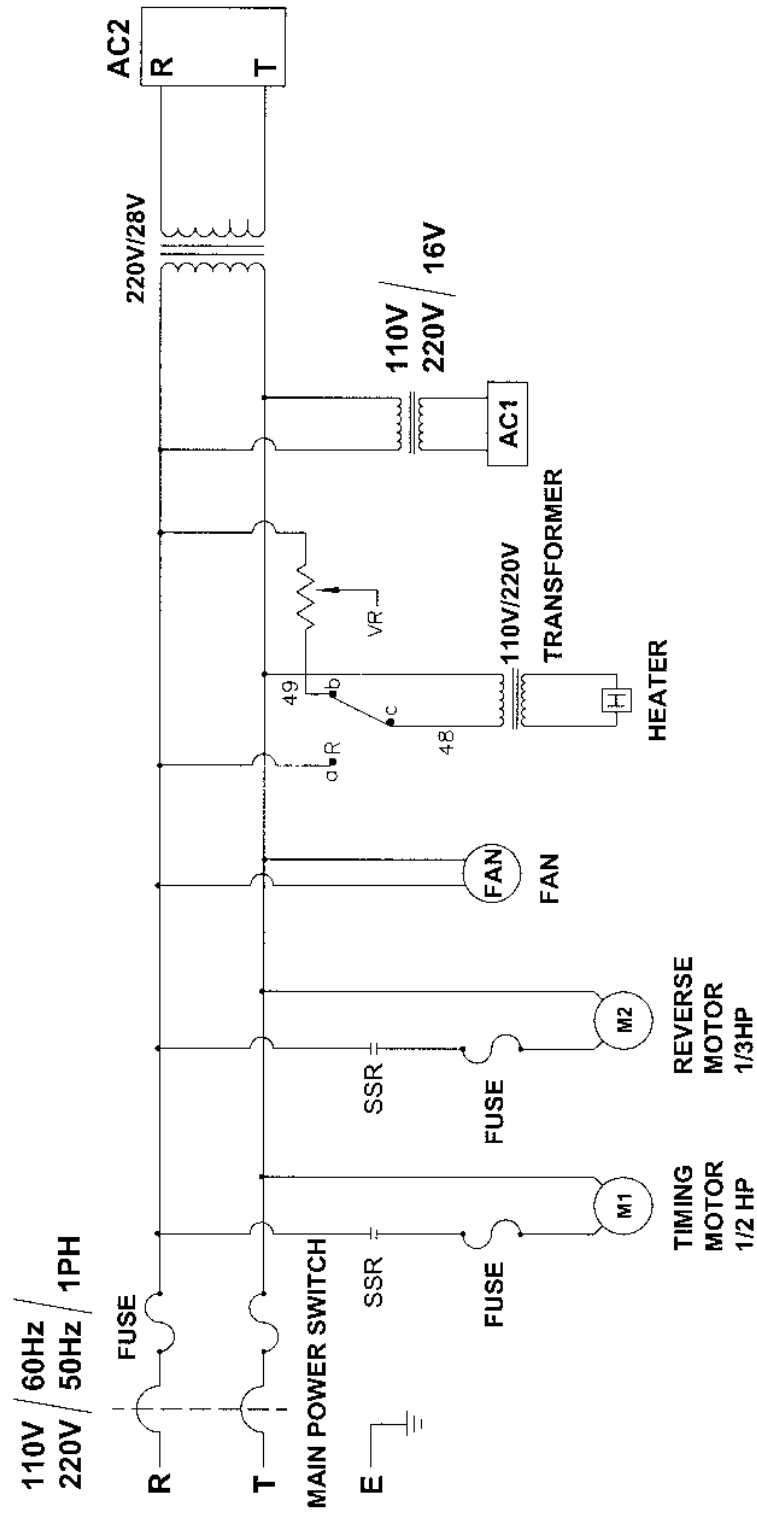

# INPUT

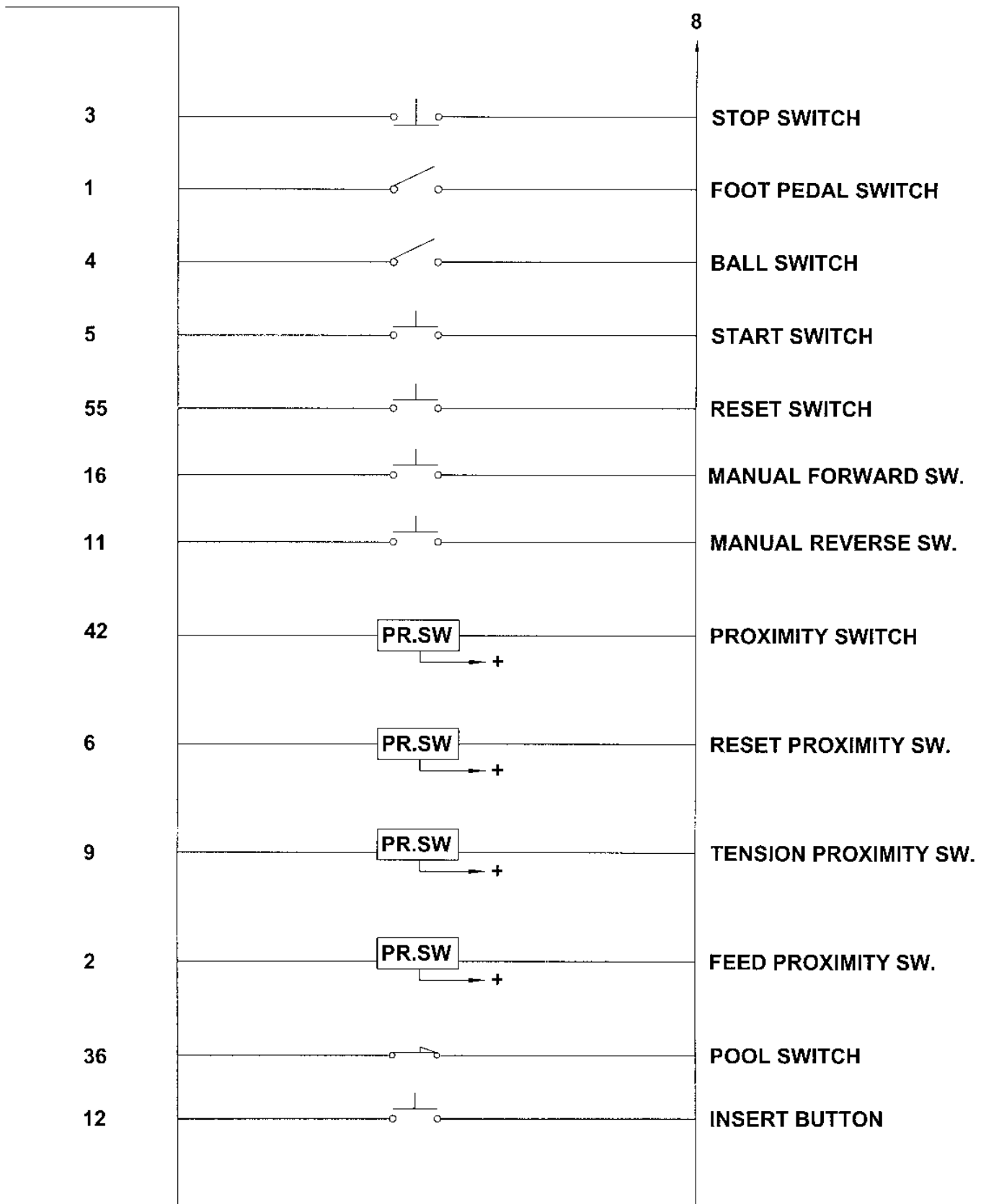



# INPUT

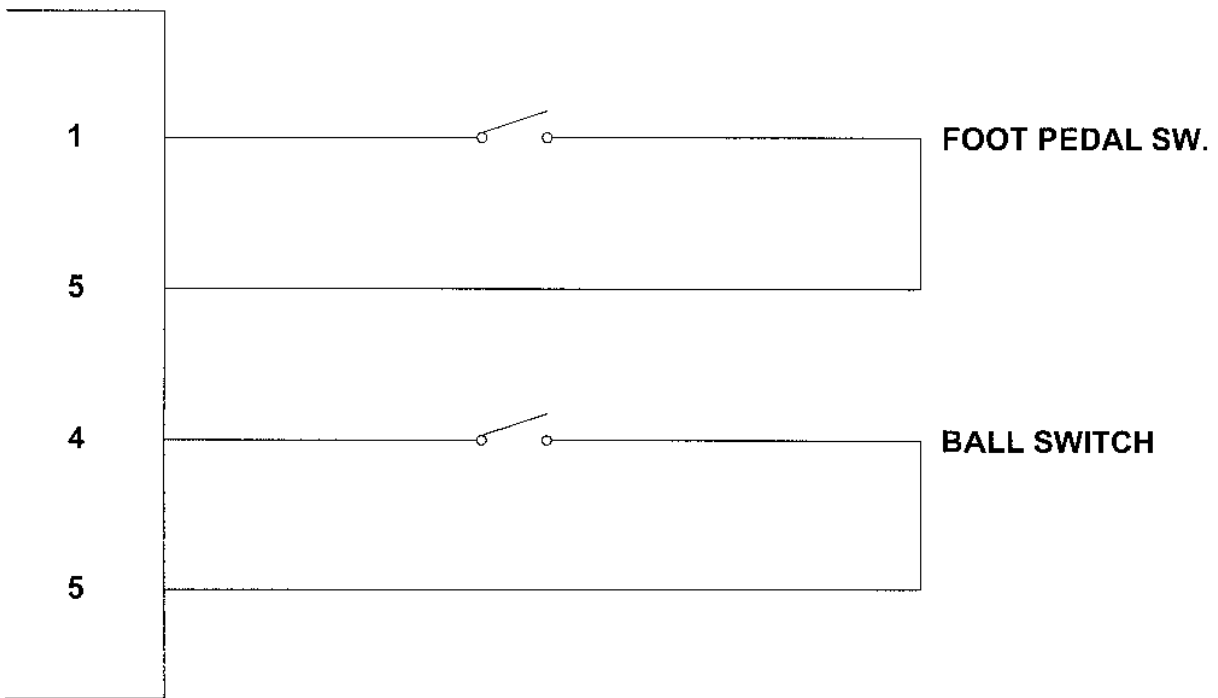
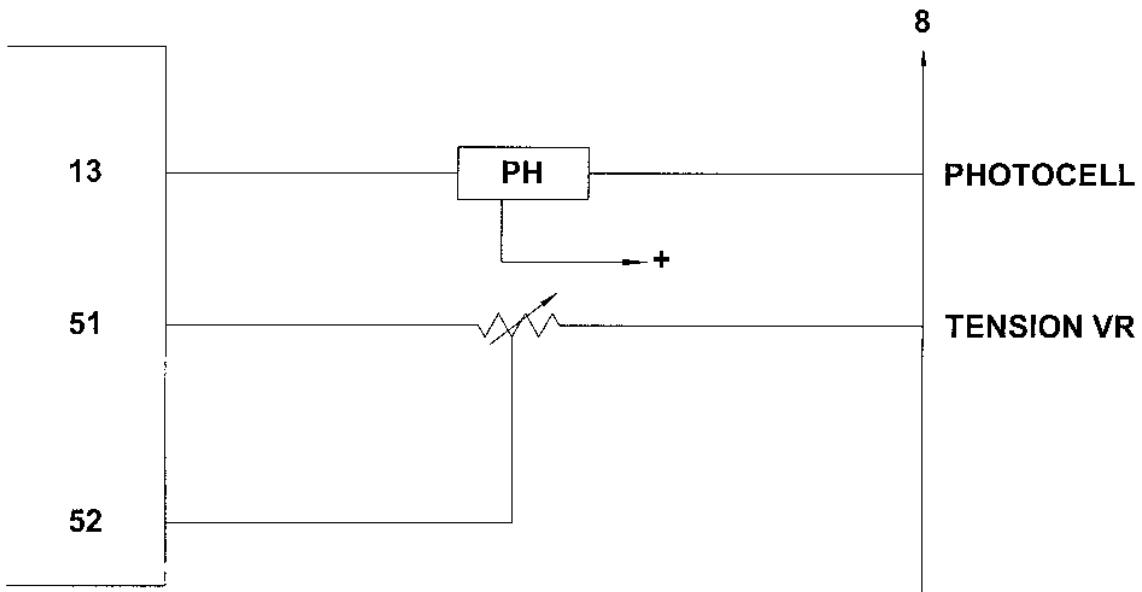

# OUT PUT

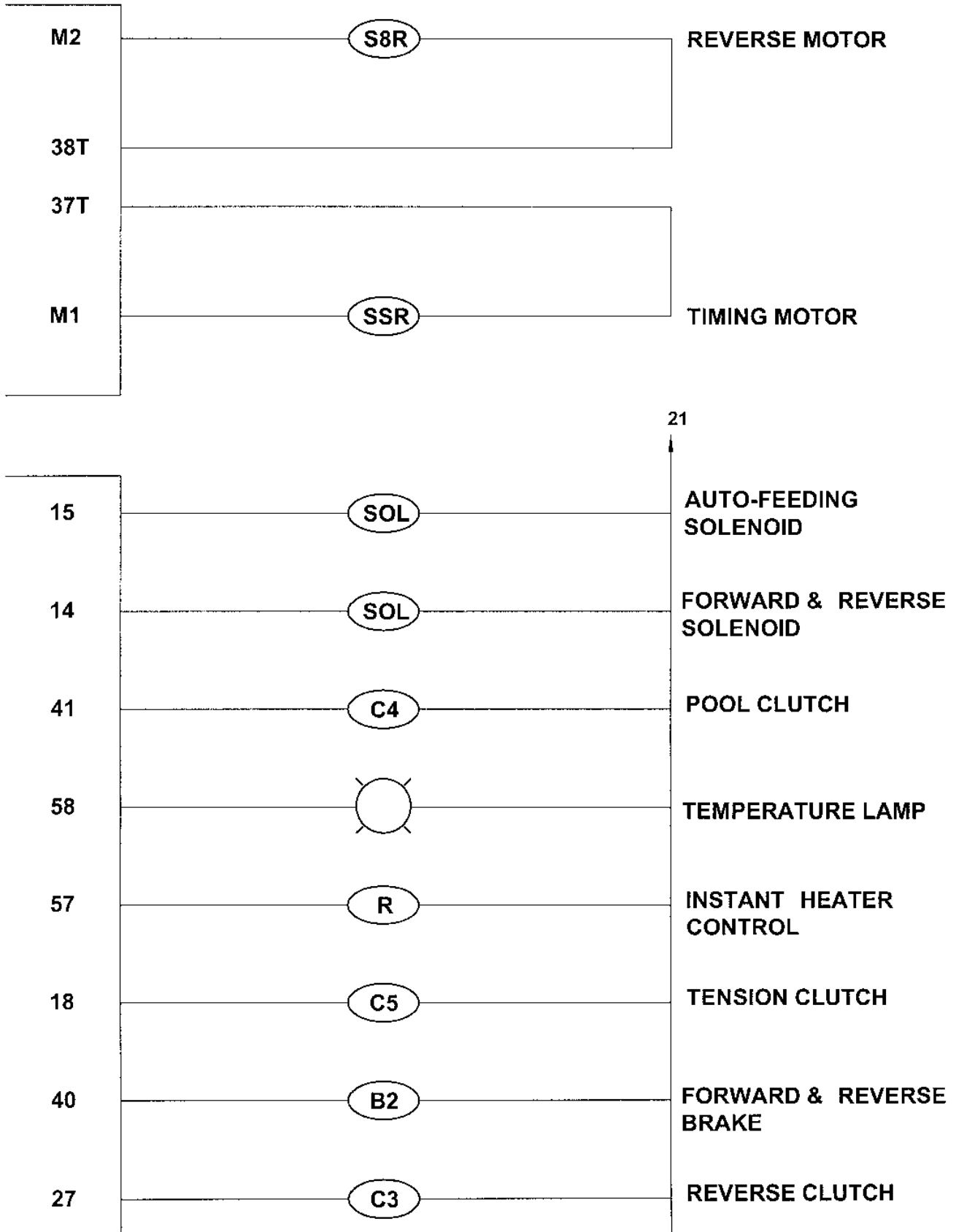

# OUT PUT

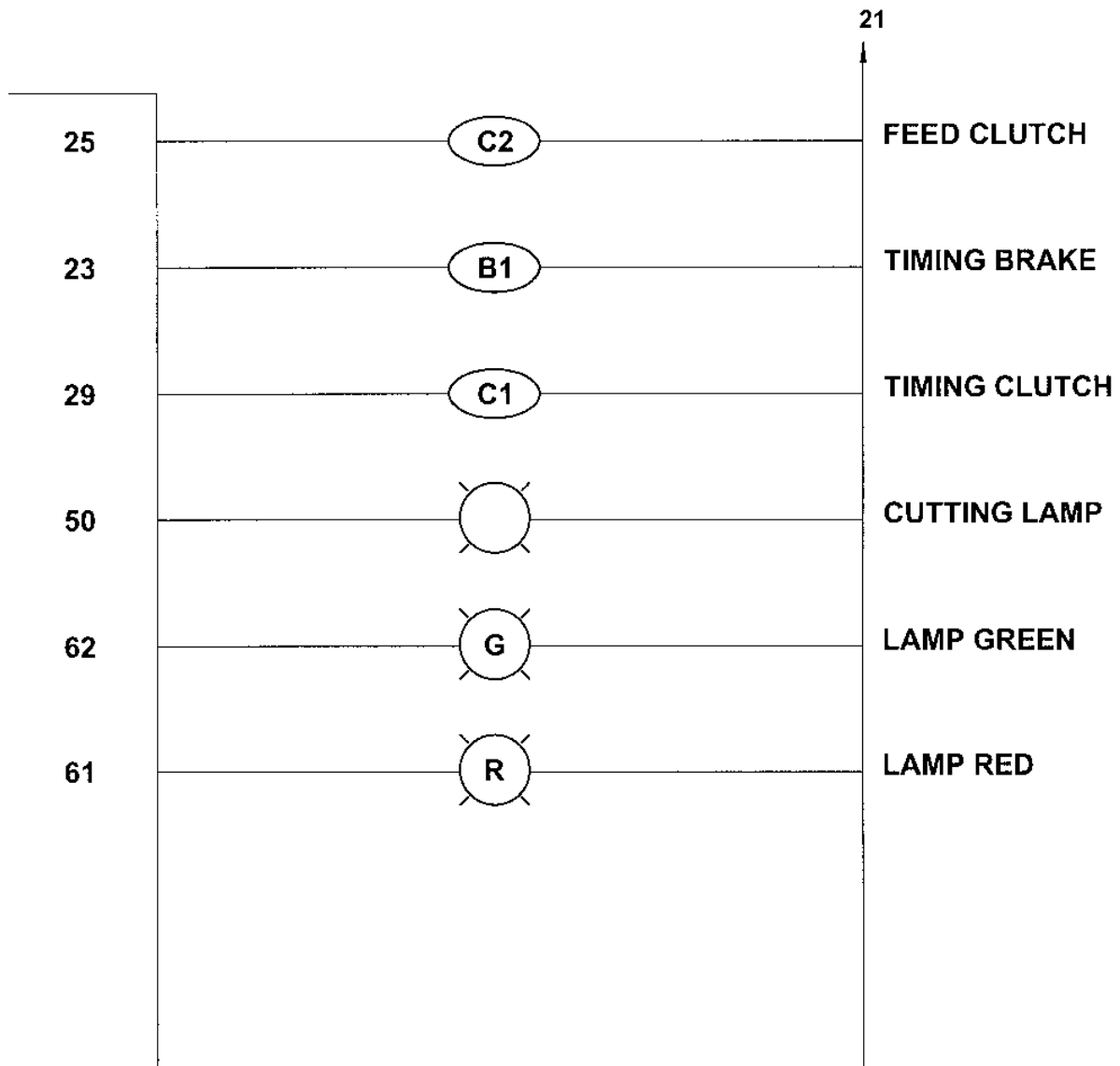

# INDEX

	PAGE
FIG. 1 CAM UNIT.....	1
FIG. 2 CUTTER BLOCK UNIT.....	3
FIG. 3 SLIDE BLOCK UNIT.....	5
FIG. 4 ROLLER BLOCK UNIT.....	7
FIG. 5 ROLLER BLOCK UNIT.....	9
FIG. 6 ELECTRIC UNIT.....	11
FIG. 7 HEATER UNIT / EXHAUST UNIT.....	13
FIG. 8 BANDWAY UNIT.....	15
FIG. 9 ARCH UNIT (NEW ALUMINUM ARCH)(3 <sup>RD</sup> GENERATION).....	17
FIG. 10 POOL UNIT.....	19
FIG. 10-1 POOL UNIT.....	21
FIG. 11 REEL UNIT.....	23
FIG. 12 BODY UNIT .....	25
FIG. 13 ELECTRIC UNIT.....	27
FIG. 14 CONTROL BOX UNIT.....	29

**\* When ordering or asking for replace parts, please state the phase, voltage and parts number.**

Fig. 1 CAM UNIT

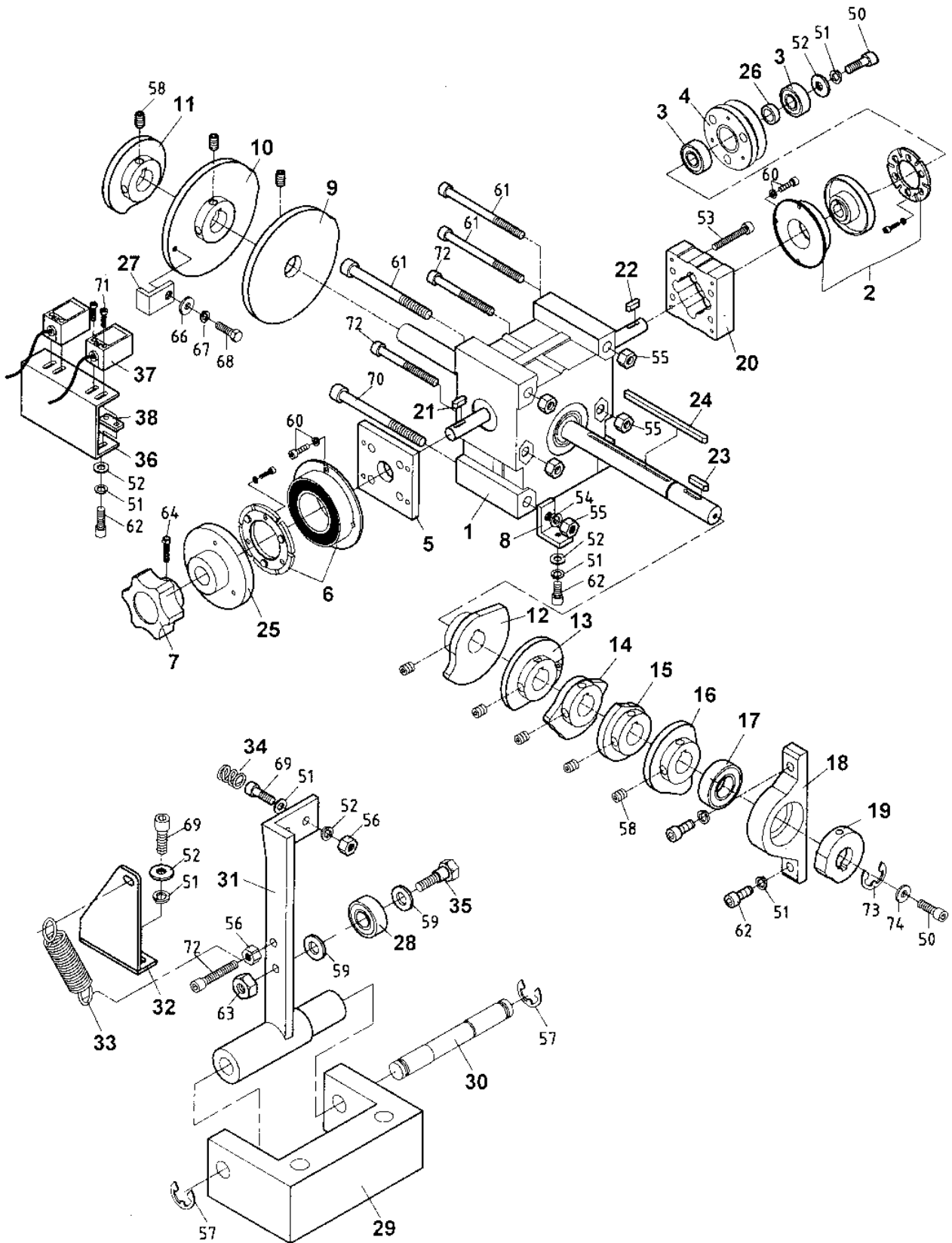
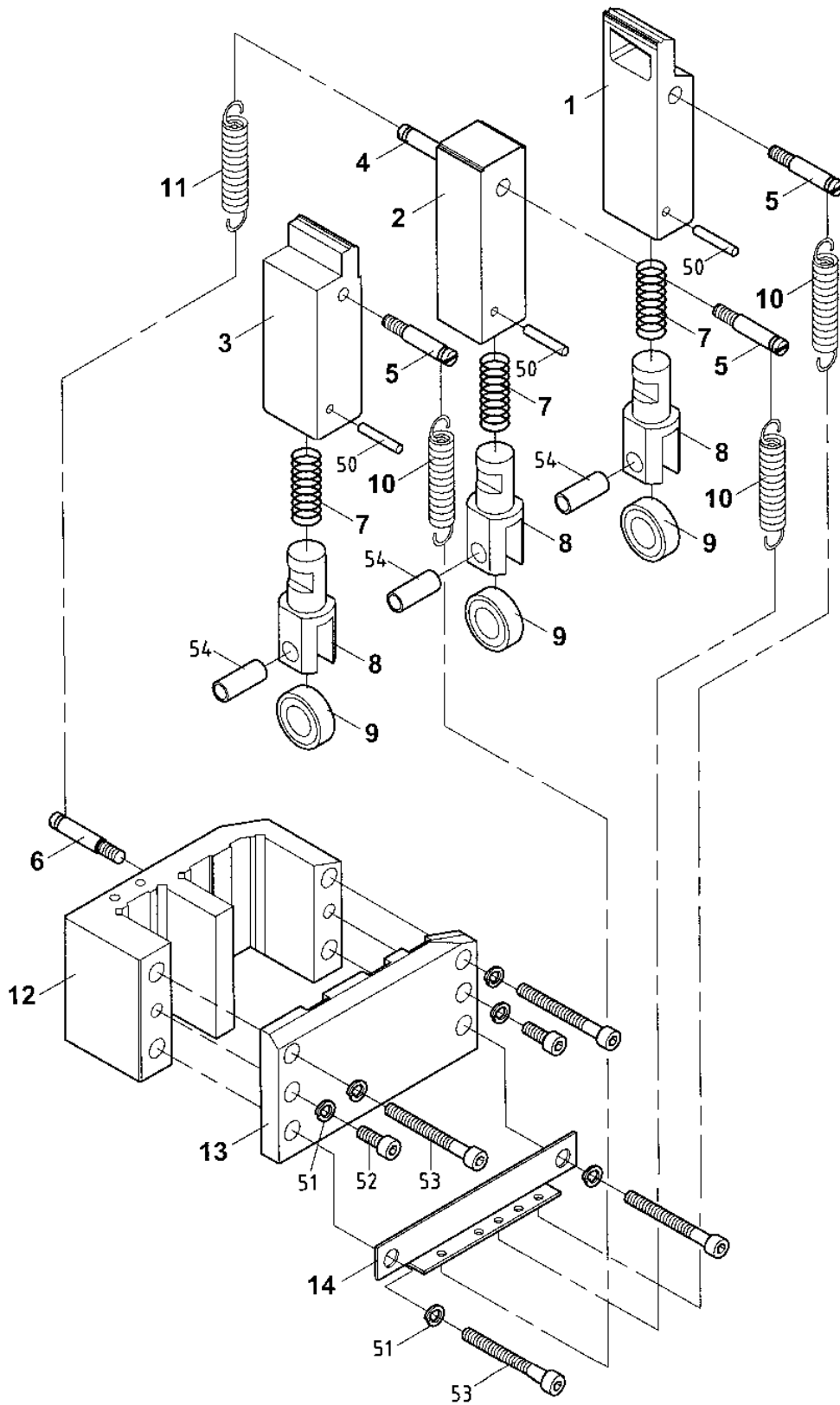

FIG.1 CAM UNIT

KEY PARTS NO.	QTY	DESCRIPTION
1	1	M01011 Gear Box
2	1	1021-05 Magnetic Clutch DC-24V 0.6K
3	2	EA-08-00D Ball Bearing 6002ZZ
4	1	M01008A Gear Box Pulley
5	1	W004000 Cap (Gear Box)
6	1	0114-00 Magnetic Brake 0.6K (T)
7	1	QA-117 Knob (Gear Box)
8	1	QA-116 Reduction Gear Mounting Seat
9	1	MX010800 Cam (LS-1)
10	1	M01004 Cam (LS-2)
11	1	M01002 Arch Cam
12	1	MX010400 Rear Clamp Cam
13	1	W000900 Heater Cam
14	1	MX010100 Universal Press Cam
15	1	MX010700 Front Clamp Cam
16	1	MX010200 Shaft Arm Cam
17	1	D-05-01 Ball Bearing 6003ZZ
18	1	QA-109 Bearing Housing
19	1	MX010300 Tension Cam
20	1	Q-009 Reduction Gear Seat (Aluminum)
21	1	KEY-4412 Key 4 x 4 x 12
22	1	KEY-5515 Key 5 x 5 x 15
23	1	KEY-5512 Key 5 x 5 x 12
24	1	KEY-55105 Key 5 x 5 x 105
25	1	M01012 Brake Pulley 12φ x 65φ
26	1	M01013 Gear Box Pulley Collar
27	1	M01004-1 Right Press Cam
28	1	2201-128 Ball Bearing 609ZZ
29	1	QH-709A Separating Arm Seat
30	1	QH-708 Separating Arm Shaft 8 x 77L
31	1	M08020 Arm
32	1	MX010600 Spring Seat
33	1	MX031400 Tension Spring
34	1	MX041100 Band Guide Spring
35	1	MX010900 Screw M6 x 12.9
36	1	M01099 Proximity Switch Bracket
37	2	1503-11 Proximity Switch PS-05N 5 mm
38	2	0123-00 Proximity Bracket Guide
50	2	SLCM6X12R Socket Screw 6 x 12
51	7	SSPWM6R-1 Spring Washer M6
52	8	SWM6X16X2R Plain Washer 6 x 16 x 2.0R
53	4	SLCM5X20R Socket Head Cap Screw 5 x 20R
54	4	SSPWM8R-1 Spring Washer 8 mm
55	5	SNM8X125R Hex. Nut 8 x 125R
56	3	SNM6X10R Hex. Nut 6 x 10R
57	2	RE-8R Ring E-8R
58	8	SAEM6X8 Socket Head Set Screw M6 x 8
59	2	SWM6X16 Plain Washer 6 x 16
60	8	SBPS4X8 Screw (P & S) 4 x 8
61	3	SLCM8X80 Socket Head Cap Screw 8 x 80
62	1	SLCM6X20R Socket Head Cap Screw 6 x 20R
63	1	SUNM6R Nut 6 x 10 x 7.5
66	1	SWM5X12R Plain Washer 5 x 12R
67	1	SSPWM5R Spring Washer 5 mm
68	1	SHM5X10 Hex. Socket Head Screw 5 x 10
69	2	SLCM6X16R Hex. Socket Cap Screw 6 x 16R
70	1	SLCM8X85 Hex. Socket Head Screw M8 x 85
71	4	SBM3X25 Philip Head Screw 3 x25
72	2	SLCM8X50R Socket Head Cap Screw 8 x 50R
73	1	RS-17 RING S-14
74	1	SWM6X21R Plain Washer 6 x 21

Fig. 2 CUTTER BLOCK UNIT



**FIG. 2 CUTTER BLOCK UNIT**

<b>KEY</b>	<b>PARTS NO.</b>	<b>QTY</b>	<b>DESCRIPTION</b>
1	MX020400	1	Holding Gripper (New)
2	MX020500	1	Plunger (New)
3	W100700	1	End Gripper
4	QB-114	1	Spring Hook 6 $\varnothing$ x 28L
5	QB-113	3	Screw 6 $\varnothing$ x 22L
6	QB-112	1	Spring Hook 6 $\varnothing$ x 15L
7	QB-213	3	Rod Compression Spring
8	QB-207	3	Press Fork
9	H-01-00B	3	Ball Bearing 608K4Z
10	QB-217	3	Tension Spring (Long) 7 $\varnothing$ x 42L
11	QB-208	1	Tension Spring (Short)
12	M02010	1	Base Plate
13	QB-102	1	Cover Plate
14	QB-115	1	Spring Hook Plate
50	PIN-322	3	Pin 3 x 22
51	SSPWM6R-1	6	Spring Washer 6 mm
52	SLCM6X20R	2	Hex. Socket Head Screw 6 x 20R
53	SLCM6X55R	4	Hex. Socket Head Screw 6 x 55R
54	PIN-814	3	V-Spring Pin (Straight) 8 $\varnothing$ x 14



**Fig. 3 SLIDE BLOCK UNIT**

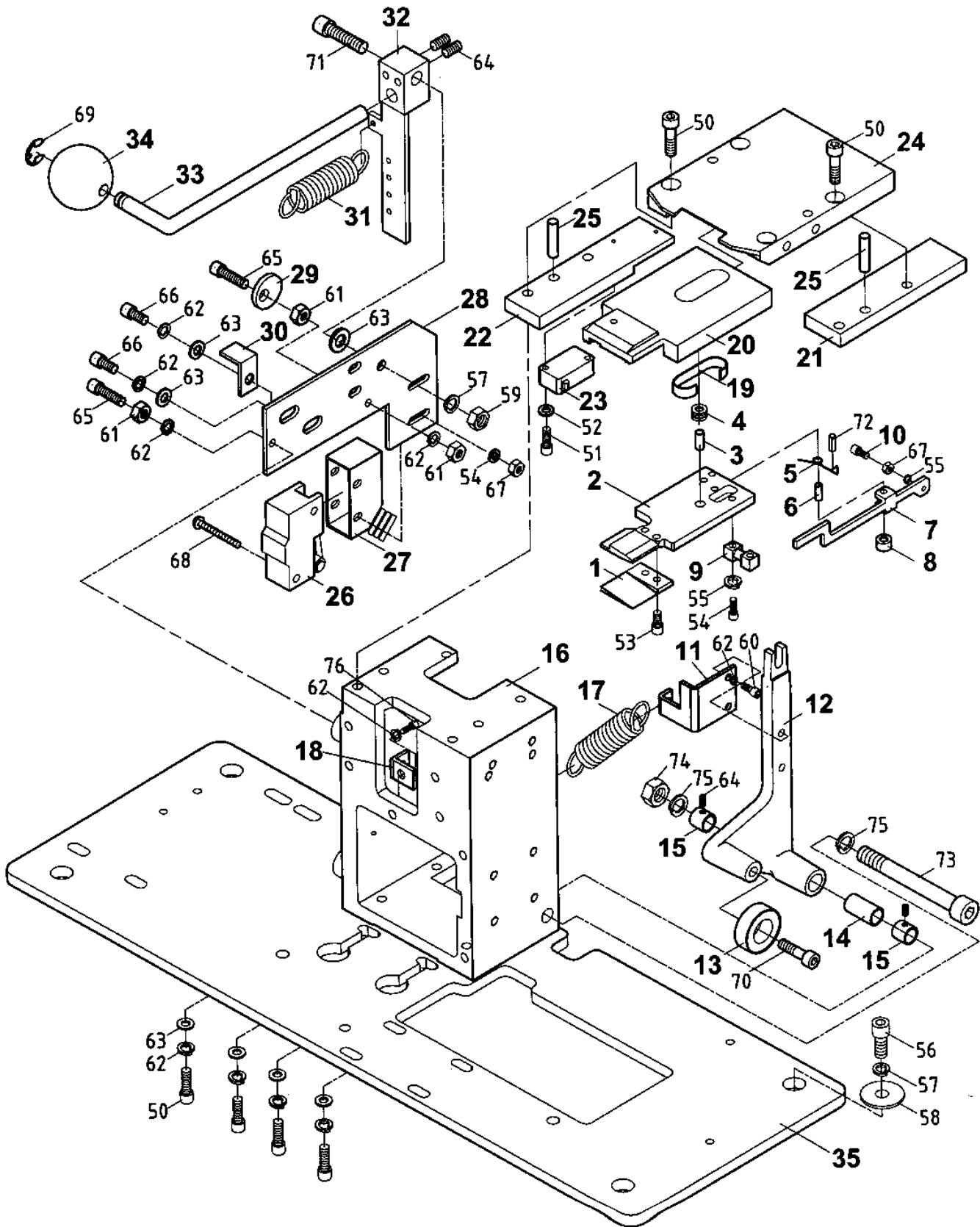
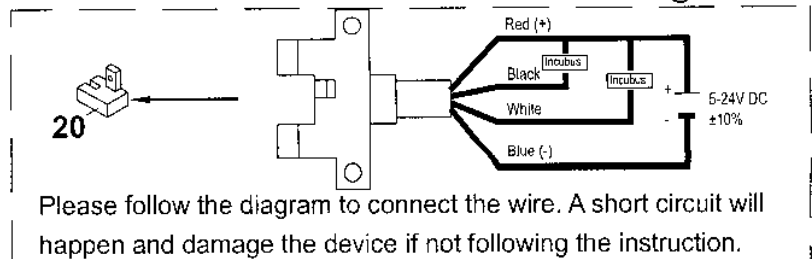
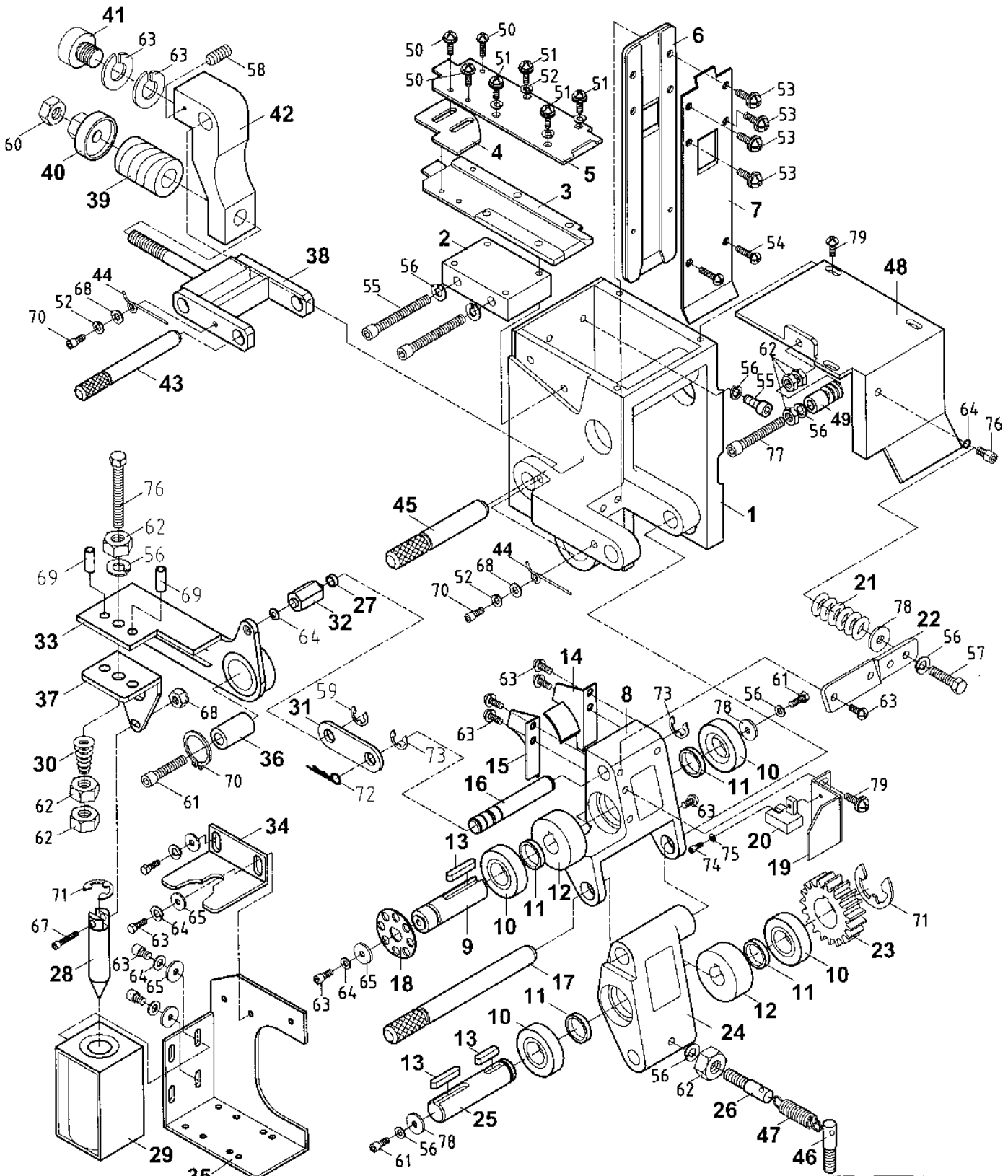

FIG.3 SLIDE BLOCK UNIT

KEY	PARTS NO.	QTY	DESCRIPTION
1	MX030500	1	Medium Slide Table Cover
2	MX030600	1	Medium Slide Table
3	W202800	1	Pin Straight 6 x 12F
4	W202900	1	Grommet
5	W201800	1	Tension Spring
6	W201700	1	Pin Straight 4 x 20.8
7	MX030700	1	Lever Actuator
8	W203800	1	Collar
9	W202400	1	Fixed Seat
10	W201600	1	Screw
11	MX031200	1	Spring hook(front)
12	MX031000	1	Separating Arm
13	2201-05E	1	Ball Bearing 628ZZ
14	W200500	1	Bearing
15	MX031100	1	Collar
16	MX030200	1	Block
17	MX031400	1	Tension Spring
18	MX031300	1	Spring hook(back)
19	W203000	1	Stopper
20	MX030400	1	Slide Table
21	W201300A	1	Guide Plate (Right)
22	W202200A	1	Guide Plate (Left)
23	MX030800	1	Proximity Switch
24	MX030100	1	Slide Table Cover
25	W203700	1	Pin Straight 6 x 24.8F
26	KSW-09	1	Safety Switch
27	KSW-11	1	Safety Switch Cover
28	M03602	1	Ball Switch Seat
29	1333-03	1	Switch Adj. Guide
30	J-11-08	1	Brake Plate (L Type)
31	1034-01	1	Pool Spring 15 mm
32	M03603	1	Switch Arm
33	M03607	1	Switch Arm
34	1333-00	1	Switch Ball 40 mm
35	MX030300	1	Base Plate
50	SLCM6X25R	8	Socket Head Cap Screw 6 x 25R
51	SBM3X15	1	Pan Head Screw 3 x 15
52	SSPWM3R	2	Spring Washer 3 mm
53	SLCM4X8R	2	Hex. Socket Head Screw 4 x 8
54	SLCM4X12R	2	Hex. Socket Head Screw 4 x 12R
55	SSPWM4R	2	Spring Washer 4 mm
56	1046-09	2	Pool Collar 9 mm
57	SSPWM8R-1	1	Spring Washer 8 mm
58	SWM8X30X3R	1	Plain Washer 8 x 30 x 3R
59	SNM8X125	1	Hex. Nut 8 x 1.25
60	SLCM6X12R	1	Socket Head Cap Screw 6 x 12R
61	SNM6X10	4	Hex. Nut 6 x 1.0
62	SSPWM6R-1	7	Spring Washer 6 mm
63	SWM6X16R	18	Plain Washer 6 x 16 x 1.0R
64	SSM5X6	2	Socket Head Cap Screw 5 x 6
65	SLCM6X30R	1	Socket Head Cap Screw 6 x 30R
66	SLCM6X16R	2	Socket Head Cap Screw 6 x 16R
67	SNM4X07R	2	Hex. Nut 4 x 0.7R
68	SBM4X30	2	Phillip Head Screw 4 x 30
69	RE-8	1	Ring E-8
70	SLCM8X20R	1	Socket Head Cap Screw 8 x 20R
71	SLCM8X35R	1	Socket Head Cap Screw 8 x 35R
72	PIN-420	1	Pin 4 x 20
73	SLCM10X125R	1	Socket Head Cap Screw 10 x 125R
74	SNM10X1.5	1	Hex. Nut 10x 1.5
75	SSPWM10R	1	Spring Washer 10 mm
76	SLCM6X10R	1	Socket Head Cap Screw 6 x 10R

**Fig. 4 ROLLER BLOCK UNIT**



Please follow the diagram to connect the wire. A short circuit will happen and damage the device if not following the instruction.

FIG. 4 ROLLER BLOCK UNIT

KEY	PARTS NO.	QTY	DESCRIPTION
1	MX041800	1	Bearing Housing (Lower)
2	M04069	1	Strap Guide Holder
3	M04068	1	Strap Insert Guide
4	M04082	1	Strap Width Adjusting Plate
5	M04067	1	Strap Guide Cover (Upper)
6	M04066A	1	Lower Strap Guide
7	M04065A	1	Strap Guide Cover (Lower)
8	M04034	1	Strap Guide (Back)
9	M04038-1	1	Feed Shaft
10	Q-515A	4	Ball Bearing 6902ZZ
11	QE-566	4	Collar
12	M0407A	2	Feed Roller
13	KEY-5514	3	Key 5 x 5 x 14
14	M04041	1	Strap Guide (Right)
15	M04040	1	Strap Guide (Left)
16	M04035	1	Feed Spring Retaining Bar
17	M04046	1	Insertion Pin
18	MX041300	1	Reversing Detector
19	MX041600	1	Detector Seat
20	MX041000	1	Sensor
21	Mx041100	1	Band Guide Spring
22	M04101	1	Spacer
23	QE-541	1	Upper Gear 15Ø x 44Ø x 16L
24	M04043	1	Strap Guide (Front)
25	M04045	1	Tension Shaft
26	W200100	1	Screw
27	QE-524	1	Collar 8Ø x 10Ø x 4L
28	M04107	1	Solenoid Pin
29	W407201	1	Solenoid DC-24V
30	MX041100	1	Band Guide Spring
31	MX040200	1	Roller Tension Plate
32	MX040600	1	Screw
33	MX040300	1	Tension Plate (A)
34	MX040100	1	Solenoid Pin Fixed Plate
35	MX041700	1	Solenoid fixed Bracket
36	MX040500	1	Shaft
37	MX040400	1	Tension Plate (B)
38	M04053	1	T type Bar unit
39	M04059	1	Tension Spring
40	M04058	1	Tension Nut
41	2204-00A	1	Cam Follower CF-10
42	M04060	1	Tension Arm
43	M04044A	1	Connecting Shaft
44	M04086	2	Pin Stopper
45	M04062A	1	Tension Pin
46	QE-540	1	Spring Hook Screw 6 x 16L
47	M04603	1	Feed Spring
48	MX041200	1	Upper Bearing Housing Cover
49	1046-09	1	Collar 9 mm
50	SBPS4X10	3	Pan Head Screw 4 x 10
51	SBM4X12	4	Phillips Head Screw 4 x 12
52	SSPWM4R	5	Spring Washer 4 mm
53	SXBWM4X12	4	Screw with washer 4 x 12
54	SBPS4X8	2	Screw 4 x 8
55	SLCM6X16	2	Socket Head Screw 6 x 16
56	SSPWM6R-1	11	Spring Washer 6 mm
57	SHM6X16	1	Hex. Bolt 6 x 16
58	SAEM6X8	1	Socket Head Set Screw 6 x 8 x 1.0
59	RE-8R	1	Ring E-8R
60	SNM8X125R	1	Hex. Nut 8 x 125R
61	SLCM6X16R	6	Socket Head Cap Screw 6 x 16R
62	SNM6X10R	8	Hex. Nut 6 x 10R
63	SB1M5X10	6	Truss Head Screw 5 x 10
64	SSPWM5R	7	Spring Washer 5 mm
65	SWM5X12R	7	Plain Washer 5 x 12R
66	SHM5X10	2	Screw 5 x 10
67	SSCM3X20	1	Socket Head Cap Screw 3 x 20
68	SUNM3R	1	Nut 3 mm
69	PIN-616	2	Pin 6 x 16
70	RS-15	1	Ring S-15
71	RE-15	1	Ring E-15
72	PIN-004	1	Pin (R Type)
73	RE-10	3	Ring E-10
74	SBM3X6	2	Screw 3 x 6
75	SSPWM3	2	Spring Washer 3 mm
76	SLCM5X12	1	Socket Head Cap Screw 5 x 12
77	SSHM6X50	1	Screw 6 x 50
78	SWM6X16R	2	Plain Washer 6 x 16R

Fig. 5 ROLLER BLOCK UNIT

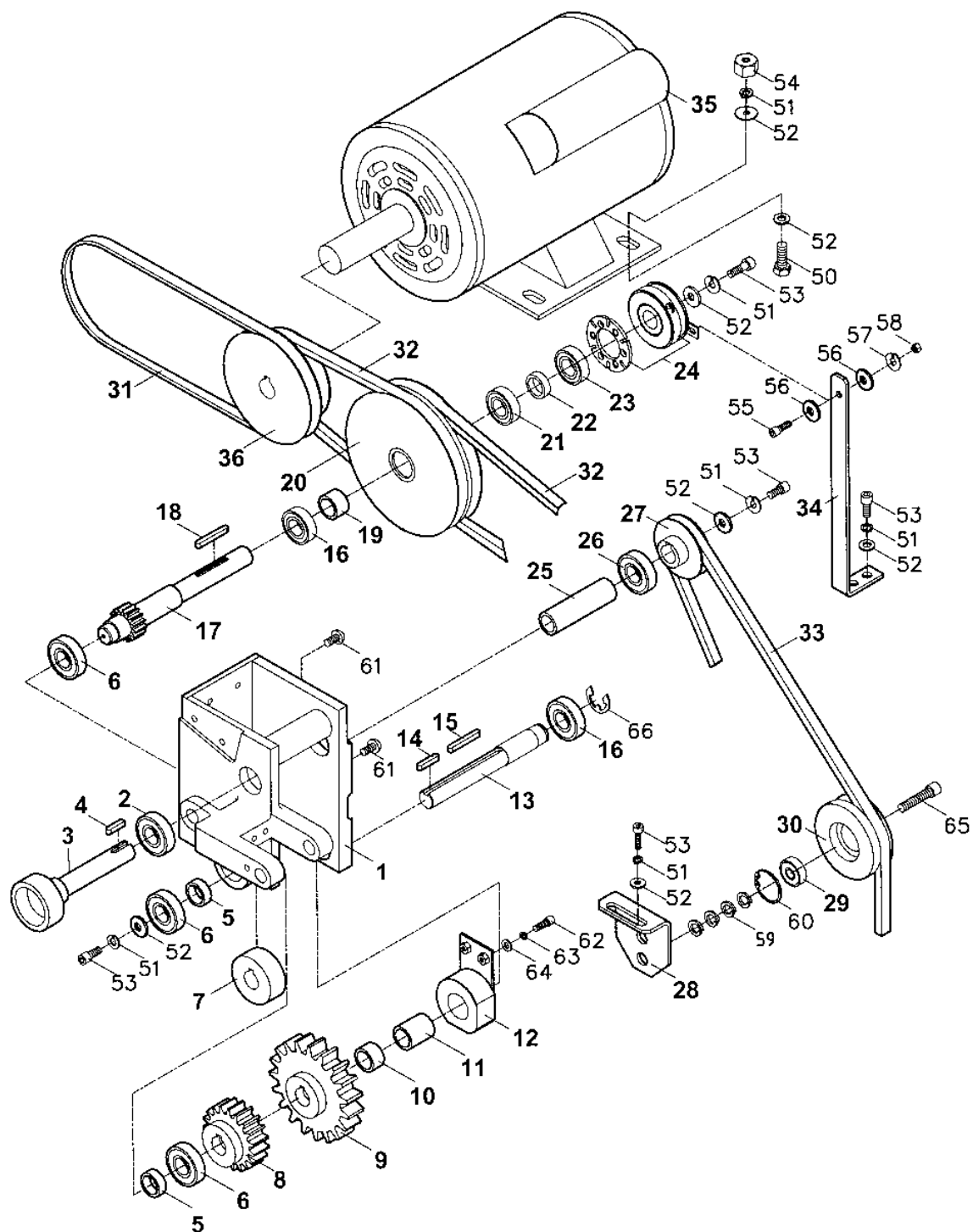

**FIG. 5 ROLLER BLOCK UNIT**

KEY	PARTS NO.	QTY	DESCRIPTION
1	MX041800	1	Bearing Housing
2	Q-515C	1	Ball Bearing 6902ZZ
3	M05052	1	Feed Roller
4	KEY-5515	1	Key 5 x 5 x 15
5	QE-542	2	Collar 15.2 Ø x 21.7Ø x 8L
6	Q-515A	3	Ball Bearing 6902ZZ
7	M04047A	1	Feed Roller
8	QE-543	1	Gear 15Ø x 44Ø x 16L
9	M05064	1	58T Gear
10	Q-589	1	Oil Seal
11	Q-588	1	One-way Bearing FC-16
12	M05075	1	One-way Housing
13	MX050400	1	Shaft
14	KEY-5512	1	Key 5 x 5 x12
15	KEY-5535	1	Key 5 x 5 x 35
16	EA-08-00A	1	Ball Bearing 6002ZZ
17	MX050300	1	Driven Shaft
18	KEY-5515	1	Key 5 x 5 x 15
19	M05072	1	Collar
20	MX050600	1	Tension Pulley (Aluminum)
21	J-12-04-1	1	Bearing 6302ZZ
22	MX050500	1	Collar
23	2201-01E	1	Ball Bearing 6202ZZ
24	1021-08	1	Clutch DC-24V 0.8K
25	M05051	1	Collar
26	EA-08-00	1	Ball Bearing 6002ZZ
27	M05050	1	Feed Pulley
28	1714-00	1	Roller Fixed Seat
29	2201-26B	1	Ball Bearing 6300ZZ
30	1715-00	1	Pulley
31	0120-07	1	V-Belt M-24 (J)
32	0120-37	1	V-Belt M-27(J)
33	0120-37	1	V-Belt M-27 (J)
34	M11103	1	Clutch Holder
35	1301-08	1	Timing Motor (1PH 220V/50HZ 1/2HP)
36	M05146	1	Timing Motor Pulley (60HZ)
	M05147	1	Timing Motor Pulley (50HZ)
50	SLCM6X20R	5	Socket Screw 6 x 20R
51	SSPWM6R-1	10	Spring Washer 6 mm
52	SWM6X16X2R	9	Washer 6 x 16 x 2.0R
53	SLCM6X16R	5	Socket Head Cap Screw 6 x 16R
54	SNM6X10R	4	Hex. Nut 6 x 1.0R
55	SLCM5X12R	1	Hex. Socket Head Screw 5 x 12
56	SWM5X12R	2	Plain Washer 5 x 12R
57	SSPWM5R	1	Spring Washer 5 mm
58	SNM5X08R	1	Hex. Nut 5 x 0.8R
59	SSPWM10R	4	Spring Washer 10 mm
60	RR-35	1	R-Stop Ring No. 35
61	SB1M4X8	2	Truss Head Screw 4 x 8
62	SBM4X20	2	Screw 4 x 20
63	SSPWM4R	2	Spring Washer 4 mm
64	SWM4X12R	2	Plain Washer 4 x 12R
65	SLCM10X50R	1	Socket Head Screw 10 x 50R
66	RE-15	1	Ring E-15

Fig. 6 ELECTRIC UNIT

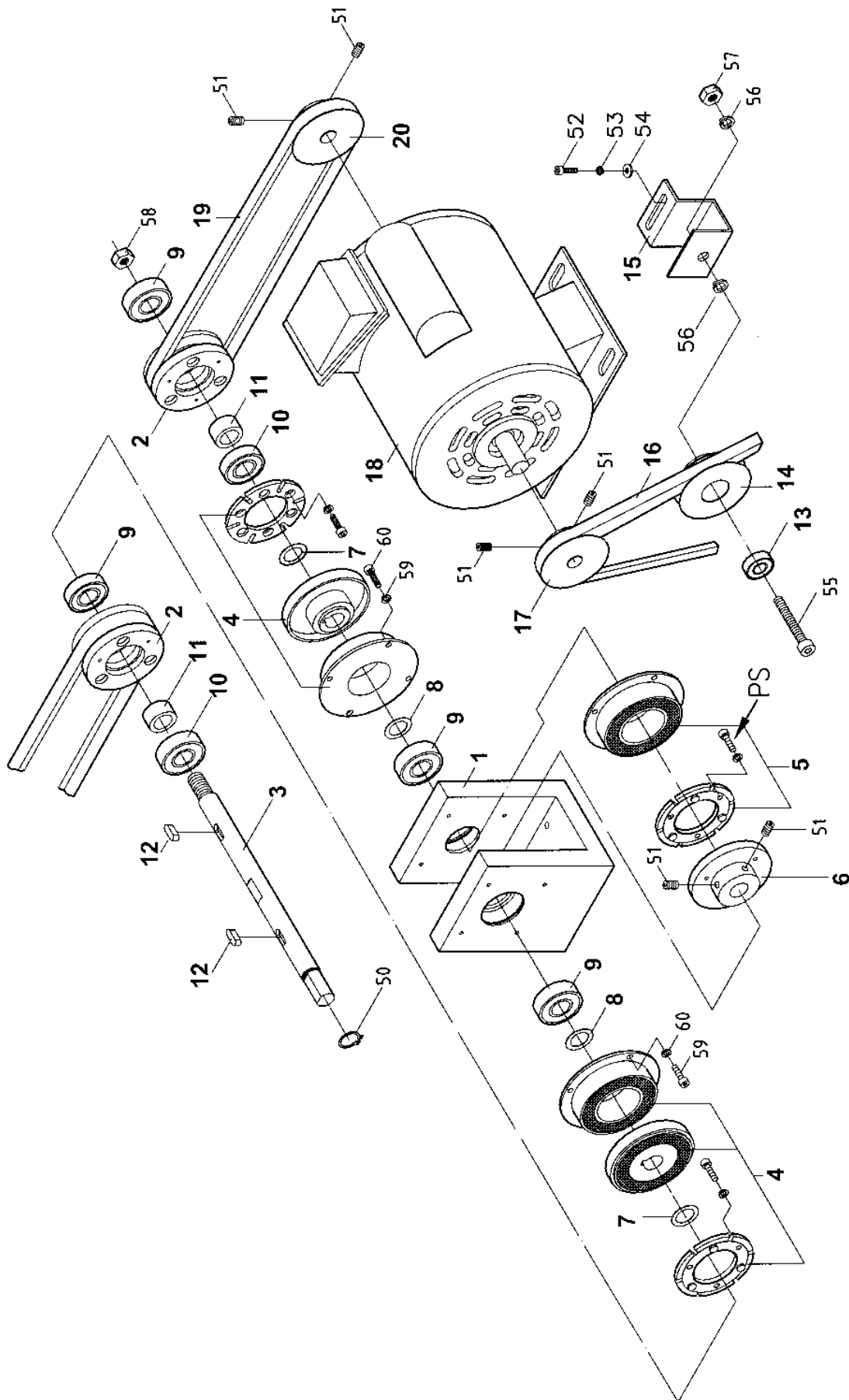
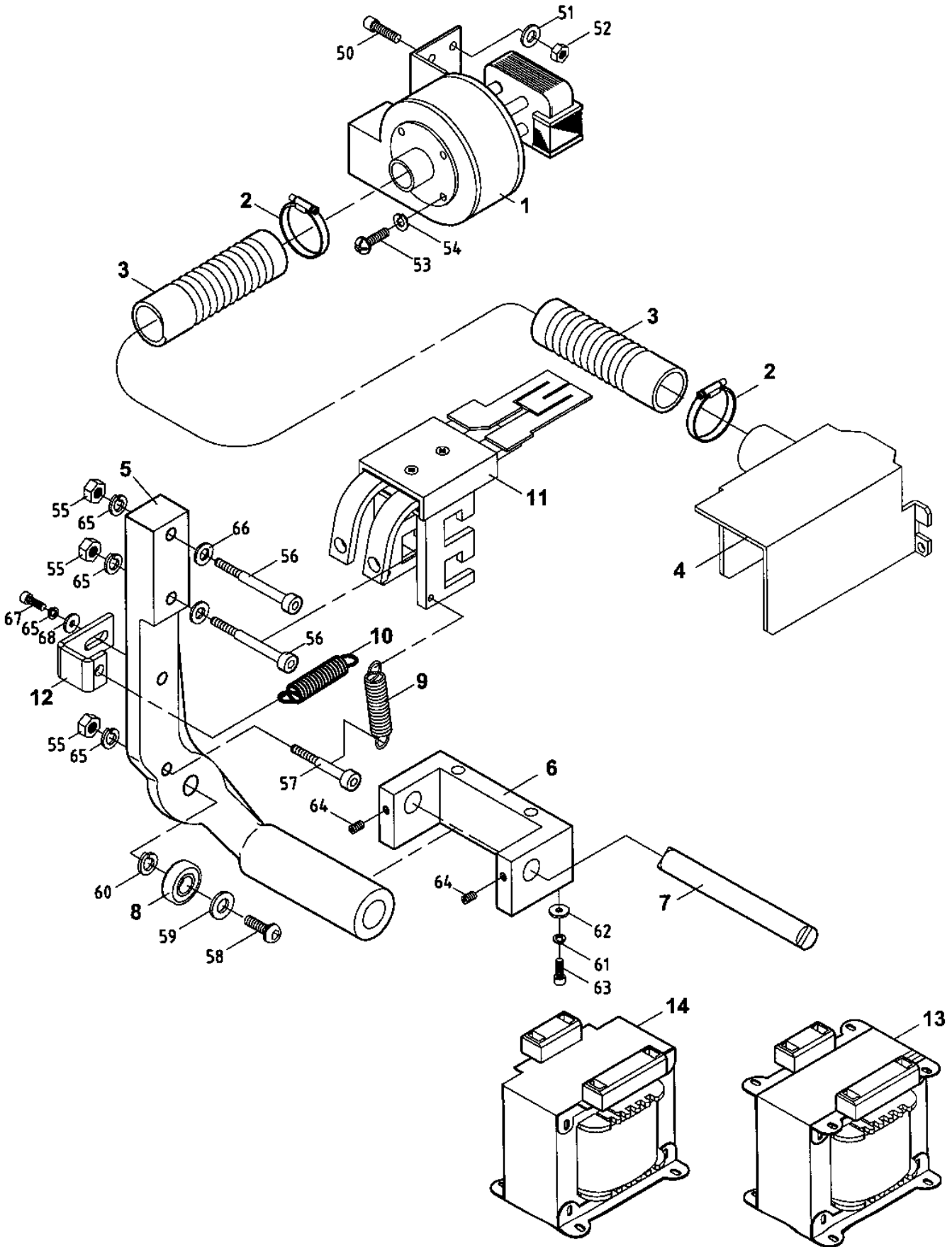

FIG. 6 ELECTRIC UNIT

KEY	PARTS NO.	QTY	DESCRIPTION
1	MX060100	1	Bearing Fixed Seat
2	1703-00	2	Clutch Pulley M63φ
3	1702-00	1	Drive Shaft 15φ
4	1021-05	2	Magnetic Clutch DC-24V 0.6K
5	0114-00	1	Magnetic Brake 0.6K
6	1705-01	1	Brake Pulley 15φ x 65φ
7	D-01-20	4	Plain Washer
8	D-01-19	2	Washer 15φ x 21φ x 0.3mm
9	2201-01	4	Ball Bearing 6202ZZ
10	EA-08-00	2	Ball Bearing 6002ZZ
11	1704-00-00	2	Brake Tube
12	KEY-5515	2	Key 5 x 5 x 15
13	2201-26B	1	Ball Bearing 6300ZZ
14	1715-00	1	Pulley 63φ
15	M06001	1	Roller Fix Seat
16	0120-25	1	V-Belt M-37 (J)
17	M10120	1	Accumlater Pulley
18	1014-06	1	Pool Motor 1PH 110V/220V 60HZ (1/3HP)
	1014-07	1	Pool Motor 1PH 220V 50HZ (1/3HP)
	1014-05	1	Pool Motor 3PH 220V/380V 50HZ (1/3HP)
	1014-08F	1	Pool Motor 1PH 240V 50HZ (1/3HP)
	1014-30	1	Pool Motor 1PH 230V 50HZ (1/3HP)
19	0120-07	1	V-Belt M-24 (J)
20	1007-00	1	Pool Feed Pulley 14φ x M56φ
50	RS-15	1	Ring S-15
51	SAEM6X10	6	Flat Screw 6 x 10 x 1.0
52	SLCM6X16R	1	Socket Head Cap Screw 6 x 16R
53	SSPWM6R-1	1	Spring Washer 6 mm
54	SWM6X16X2R	1	Washer 6 x 16 x 2.0R
55	SLCM10X50R	1	Socket Head Screw 10 x 50R
56	SSPWM10R	7	Spring Washer 10 mm
57	SNM10X15R	1	Hex. Nut 10 mm
58	SNM12X125R	2	Hex. Nut 12 x 1.25R
59	SLCM4X8R	8	Hex. Socket Head Screw 4 x 8
60	SSPWM4R	8	Spring Washer 10 mm



**Fig. 7 HEATER UNIT/EXHAUST UNIT**



**FIG.7 HEATER UNIT / EXHAUST UNIT**

<b>KEY</b>	<b>PARTS NO.</b>	<b>QTY</b>	<b>DESCRIPTION</b>
1	QE-704-1	1	Smoke Collector 110V 50HZ/60HZ
	QE-704-2	1	Smoke Collector 220V 50HZ/60HZ
2	0409-08	2	Hose Band
3	Q-710	1	Coil Tube
4	MX070400	1	Smoke Collect Box
5	MX070700	1	Heater Arm
6	MX070500	1	Heater Arm Seat
7	MX070600	1	Heater Arm Seat Shaft
8	W801800	1	Ball Bearing 698ZZ
9	W901500	1	Heater Spring
10	W901600	1	Heater Drank Spring
11	MX070100-AS1	1	Heater Assembly
12	MX070800	1	Spring hook
13	1415-23	1	Transformer (110V-440V)
14	MX070200	1	Transformer (Heater
50	SXBWM4X15R	2	Cross Screw Washer 4 x 15R
51	SSPWM4R	2	Spring Washer 4 mm
52	SNM4X07R	2	Hex. Nut 4 x 0.7R
53	SBM3X10	3	Phillips Head Screw 3 x 10
54	SSPWM3R	3	Spring Washer 3 mm
55	SNM5X08R	2	Hex. Nut 5 x 0.8R
56	SLCM5X45	2	Socket Head Cap Screw 5 x 45
57	SLCM5X40	1	Hex. Socket Head Screw 5 x 40
58	SBH8X16	1	Screw 8 x 16
59	SWM8X16	1	Plain Washer 8 x 16
60	SSPWM8R	1	Spring Washer 8 mm
61	SSPWM6R-1	2	Spring Washer 6 mm
62	SWM6X16R	2	Washer 6 x 16R
63	RS-08-1	2	Socket Head Cap Screw 6 x 20R
64	SSM6X6	2	Set Socket Cap Screw 6 x 6
65	SSPWM5R	4	Spring Washer 5 mm
66	SWM5X12R	2	Plain Waher 5 x 12R
67	SLCM5X12R	1	Socket Head Cap Screw 6 x 12
68	SWM5X16X2R	1	Spring Washer 5x16x2R

Fig. 8 BAND WAY UNIT

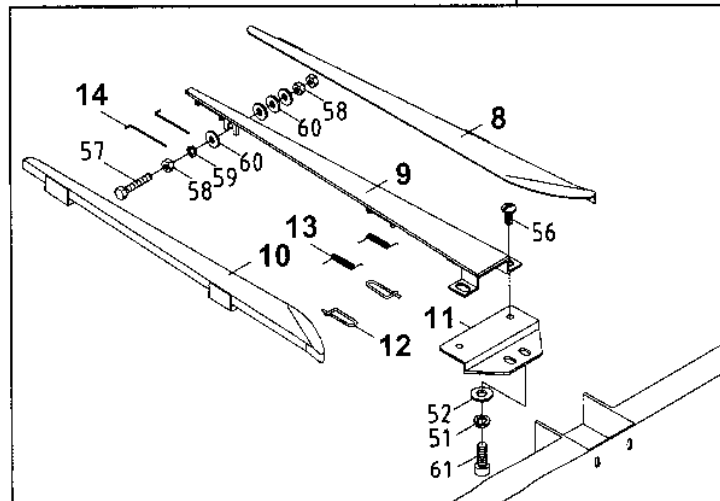
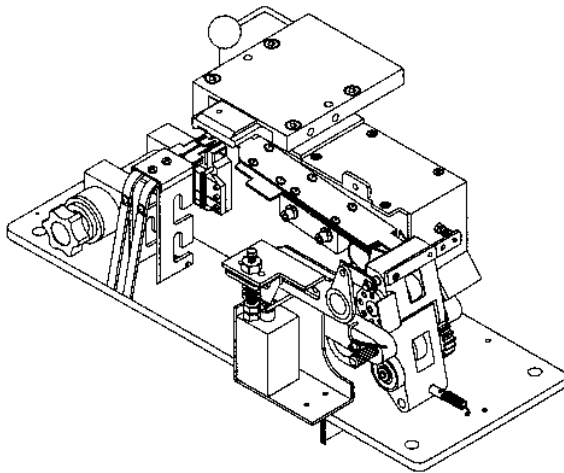
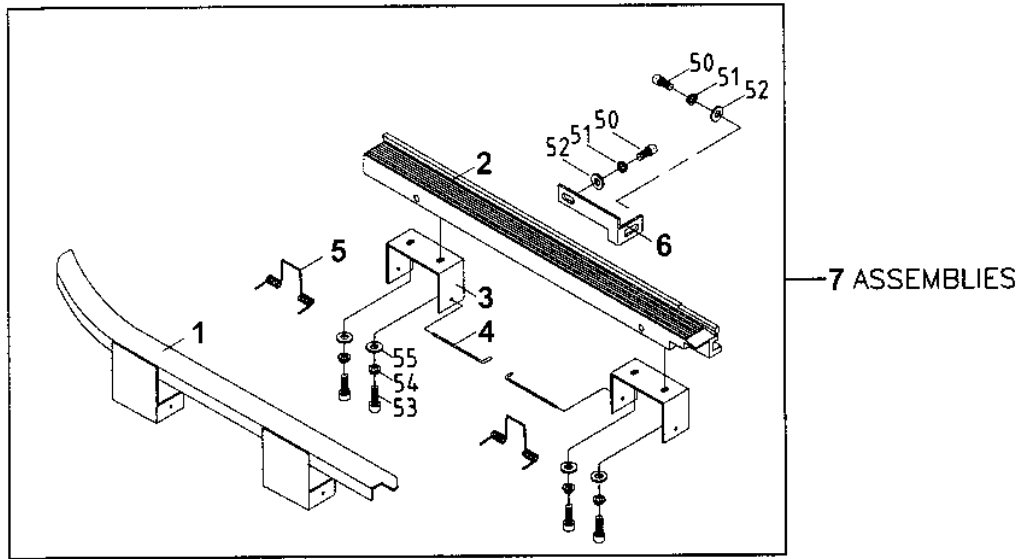

**FIG. 8 BANDWAY UNIT (3<sup>rd</sup> Generation Aluminum Arch)**

KEY	PARTS NO.	QTY	DESCRIPTION
1	M08024-AS0	1	Left Bandway Guide Assembly (for Arch: 800W)
	M08024-AS10	1	Left Bandway Guide Assembly (for Arch: 600W)
2	MX080300	1	Left Bandway Unit (for Arch: 800W)
	MX080310	1	Left Bandway Unit (for Arch: 600W)
3	0987-05	2	Left Bandway Connector
4	0806-00	2	Left Bandway Flap Pin
5	0810-02	2	Left Bandway Flap Spring
6	MX080200	1	Fixed Plate
7	MX080300-UN0	1	Left Bandway Unit (for Arch: 800W)
	MX080301-UN1	1	Left Bandway Unit (for Arch: 1000W)
	MX080310-UN10	1	Left Bandway Unit (for Arch: 600W)
8	M08001R-AS10	1	Right Bandway Flap Assembly (R) 6 mm (for Arch: 600W)
	M08002R-AS0	1	Right Bandway Flap Assembly (R) 9 mm (for Arch: 800W)
	M08003R-AS0	1	Right Bandway Flap Assembly (R) 12 mm (for Arch:800W)
	M08004R-AS0	1	Right Bandway Flap Assembly (R) 15 mm (for Arch:800W)
9	M08010-AS10	1	Right Bandway Assembly 6 mm (for Arch: 600W)
	M08011-AS0	1	Right Bandway Assembly 9mm (for Arch: 800W)
	M08012-AS0	1	Right Bandway Assembly 12 mm (for Arch: 800W)
	M08013-AS0	1	Right Bandway Assembly 15 mm (for Arch: 800W)
10	M08001L-AS10	1	Right Bandway Flap Assembly (L) 6 mm (for Arch: 600W)
	M08002L-AS0	1	Right Bandway Flap Assembly (L) 9 mm (for Arch: 800W)
	M08003L-AS0	1	Right Bandway Flap Assembly (L) 12 mm (for Arch: 800W)
	M08004L-AS0	1	Right Bandway Flap Assembly (L) 15 mm (for Arch: 800W)
11	MX080100	1	Right Bandway Fixed Seat
12	0807-00	2	Right Bandway Flap Pin
13	0808-00	2	Right Bandway Flap Spring
14	0811-00	2	Right Bandway Flap Pin
15	MX0804010-UN10	1	Righth Bandway Unit 6 mm (for Arch: 600W)
	MX080500-UN0	1	Right Bandway Unit 9 mm (for Arch: 800W)
	MX080600-UN0	1	Right Bandway Unit 12 mm (for Arch: 800W)
	MX080700-UN0	1	Right Bandway Unit 15 mm (for Arch: 800W)
50	SLCM5X16R	2	Socket Head Cap Screw 6 x 16R
51	SSPWM5	6	Spring Washer 5 mm
52	SWM5X12R	6	Plain Washer 5 x 12R
53	SBM4X10	4	Screw 4 x 10
54	SSPWM4	4	Spring Washer 4 mm
55	SWM4X10	4	Plain Washer 4mm
56	SB1M6X15	2	Truss Head Screw 6 x 15
57	SSHM6X50	1	Screw 6 x 50
58	SNM6X10R	3	Hex. Nut 6 x 1.0R
59	SSPWM6R-1	1	Spring Washer 6 mm
60	SWM6X16X2R	3	Washer 6 x 16 x 2.0R
61	SLCM5X16R	2	Socket Head Cap Screw 5 x 16R

**NOTE:**

The above parts are all suitable for our standard size (800W x 600H or 600W x 400H) of arch. If you need to place an order of parts for smaller or bigger size of arch, please state your arch size or your purchase order No. We will offer the item No. for your study accordingly.

Fig. 9 ARCH UNIT

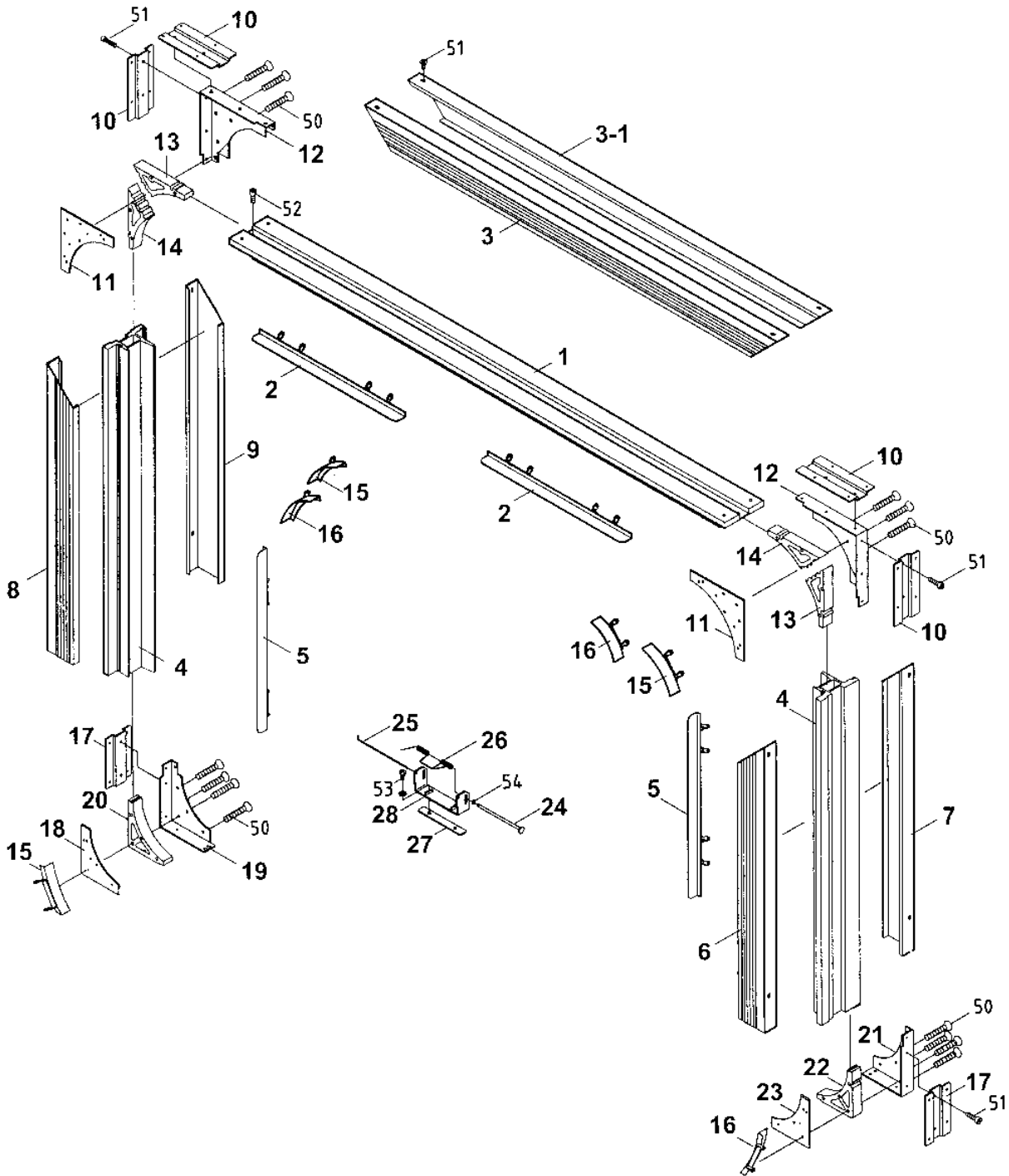

FIG. 9 ARCH UNIT (NEW ALUMINUM ARCH) (3<sup>RD</sup>)

KEY	PARTS NO.	QTY	DESCRIPTION
1	MX090100	1	Arch Frame (W) (800W)
2	MX090800	2	Arch Flap (Up)
3	MX090300	1	Iron Arch Cover (800W) (Front)
	0982B-20		Aluminum Arch Cover (800W) (Front)
3-1	MX091300	1	Arch Cover (800W) (Back)
	0982C-20		Aluminum Arch Cover (800W) (Back)
4	MX090200	2	Arch Frame (H) (600H)
5	MX090900	2	Arch Flap (L & R)
6	MX090400	1	Iron Arch Cover (600H) (RF)
	0983B-00R		Aluminum Arch Cover (600H) (RF)
7	MX090500	1	Iron Arch Cover (600H) (RB)
	0983C-00R		Aluminum Arch Cover (H) (600H) (RB)
8	MX090600	1	Iron Arch Cover (600H) (LF)
	0983B-00L		Aluminum Arch Cover (H) (600H) (LF)
9	MX090700	1	Iron Arch Cover (600H) (LB)
	0983C-00L		Aluminum Arch Cover (600H) (LB)
10	0984-26	4	Fixed Plate (Up)
11	0984-23D	2	Arch Frame (UB)
12	0984-23C	2	Arch Frame (UF)
13	0984-12A	2	Arch Frame (U/A)
14	0984-12B	2	Arch Frame (U/B)
15	0985-33	3	Arch Flap (Corner)
16	0985-34	3	Arch Flap (Corner)
17	0984-27	2	Fixed Plate (Down)
18	0984-24D	1	Arch Frame (DFL)
19	0984-25A	1	Arch Frame (DBL)
20	0984-13R	1	Arch Frame (DL)
21	0984-25B	1	Arch Frame (DBR)
22	0984-13L	1	Arch Frame (DR)
23	0984-24D	1	Arch Frame (DFR)
24	0986-10	8	Arch Hinge Pin
25	0912-00	8	Flap Hinge Shaft (B)
26	0916-00	8	Arch Flap Spring
27	0984-28	8	Arch Flap Fixed Plate
28	0909-00	8	Arch Flap (A)
50	SFM5X31R	20	Flat Head Cap Screw 5 x 31R
51	SBHH5X10	22	Hex. Screw 5 x 10
52	SCMPS6X15	6	Hex. Screw 6 x 14
53	SBPS4X8	36	Screw (P & S) 4 x 8

Fig. 10 POOL UNIT

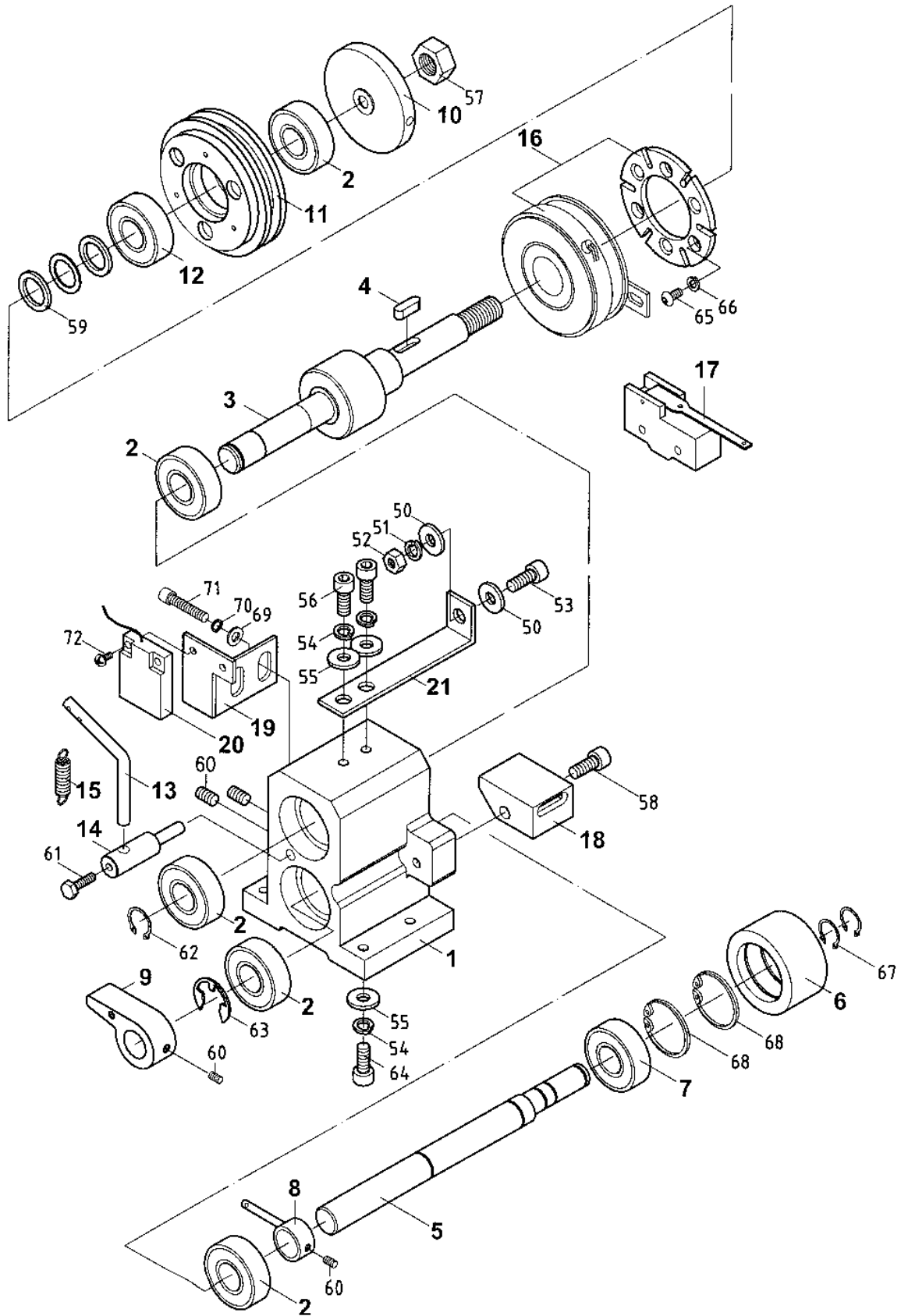

FIG.10 POOL UNIT

KEY	PARTS NO.	QTY	DESCRIPTION
1	1001-03A	1	Pool Feed Bearing Housing
2	2201-01C	5	Ball Bearing 6202ZZ
3	1004-01	1	Pool Feed Roller Shaft (Single Phase)
4	KEY-5514	1	Key 5 x 5 x 14
5	MX100900	1	Accumulation Roller Shaft
6	1003-00	1	Pool Feed Lower Roller
7	2201-00C	1	Ball Bearing 6201ZZ
8	M10021B-AS1	1	Tension Adjustment Set (B)
9	1037-00A	1	Knob
10	1002-05	1	Pulley
11	1703-00A	1	Clutch Pulley M82Ø
12	EA-08-00A	1	Ball Bearing 6002ZZ
13	1010-01B	1	Pool Adj. Shaft
14	1013-00	1	Pool Adj. Shaft
15	1010-02A	1	Pool Adj. Spring L75.2 mm
16	1021-00	1	Clutch DC-24V 0.6K
17	W802400	1	Limit Switch
18	1006-00A	1	Pool Feed Shooter (6-7 mm)
	1006-01A	1	Pool Feed Shooter (8-9 mm)
	1006-02A	1	Pool Feed Shooter (12mm)
	1006-03A	1	Pool Feed Shooter (15 mm)
19	MX100500	1	Detector Fixed Plate
20	MX100600	1	Proximity Switch
21	0724-00	1	Adjust Base (L Type)
50	SWM5X12R	2	Plain Washer 5 x 12R
51	SSPWM5R	1	Spring Washer 5 mm
52	SNM4X07R	1	Hex. Nut 4 x 0.7R
53	SLCM4X12R	1	Hex. Socket Screw 4 x 12
54	SSPWM6R-1	9	Spring Washer 6 mm
55	SWM6X16R	9	Washer 6 x 16R
56	SLCM6X12R	2	Hex. Bolt 6 x 12
57	SNM12X125R	1	Hex. Nut 12 x 1.25R
58	SLCM6X35R	1	Hex. Socket Head Screw 6 x 35R
59	D-02-04	2	Clutch Interval Tube 0.10 mm
60	SAEM5X6	5	Socket Cap Screw 5 x 6 x 0.8
61	SHM5X12	1	Hex. Bolt 5 x 12
62	RR-15	1	Ring R-15
63	RE-12	2	Ring E-12
64	SLCM6X20R	6	Socket Screw 6 x 20
65	SBH4X8	6	Socket Screw 4 x 8
66	SSPWM4R	6	Spring Washer 4 mm
67	RSS-12	3	Ring S-12
68	RS-32	2	Ring S-32
69	SWM4X10R	2	Plain Washer 4 x 10R
70	SSPWM4R	2	Spring Washer 4 mm
71	SLCM4X10	2	Hex. Socket Head Bolt M4 x 10
72	SB1M5X10	2	Truss Head Screw 5 x 10



Fig. 10-1 POOL UNIT

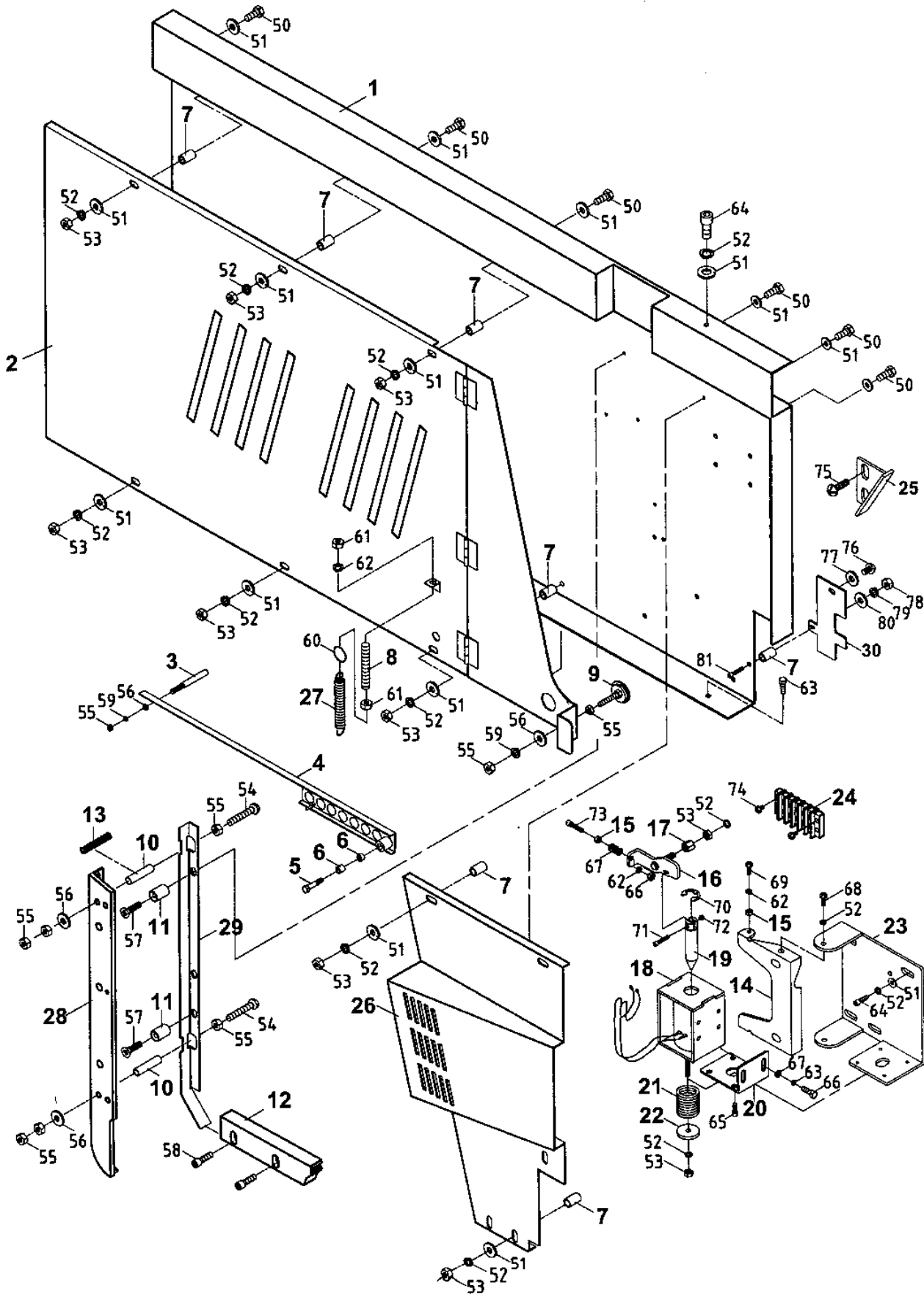

FIG. 10-1 POOL UNIT

KEY	PARTS NO.	QTY	DESCRIPTION
1	MX102000	1	Pool Box (Back) (Standard)
2	MX102100-AS0	1	Pool Box (Front) (Standard)
3	W700600	1	Working Bar
4	MX102900	1	Balance Bar Assembly 15 mm
	MX102800	1	Balance Bar Assembly 12 mm
	MX102700	1	Balance Bar Assembly 9 mm
	MX102600	1	Balance Bar Assembly 5-6 mm
5	W701200	1	Balance Bar Screw
6	W701000A	2	Ball Bearing
7	1046-06	11	Pool Collar 5-6 mm
	1046-09	10	Pool Collar 9 mm
	1046-09	10	Pool Collar 12 mm
	1046-15	10	Pool Collar 15 mm
8	W703600	1	Pool Box Adj. Screw
9	M07023	1	Magnet Catch Assembly
10	W704000	4	Collar L25 mm /5-6 mm
	W704001	4	Collar L30 mm / 9 mm
	W704003	4	Collar 12 mm
11	M10300	3	Collar 6 mm
	M10301	3	Collar 9 mm
	M10303	3	Collar 15 mm
12	M07013C	1	Pool Strap Guide 6 mm
	M07014C	1	Pool Strap Guide 9 mm
	M07015C	1	Pool Strap Guide 15 mm
	M07016C	1	Pool Strap Guide 12 mm
13	W702903	1	Bandway Spring 9-15 mm
	W702900	1	Bandway Spring 5-6 mm
14	MX100300	1	Feed Shooter Fixed Plate
15	2201-138	3	Ball Bearing 605ZZ (C)
16	MX100400	1	Feed Shooter Connector
17	MX101100	1	Screw
18	W407202	1	Feeding Solenoid DC-24V
19	M04107	1	Solenoid Pin
20	MX100200	1	Solenoid Adj. Seat
21	QE-5630	1	Tension Spring 27L
22	MX101200	1	Fixed Nut
23	MX100100	1	Solenoid Fixed Seat
24	KAD-09-35	1	Terminal Bracket 5P
25	MX102400	1	Strap Guide 6 mm
	MX102401	1	Strap Guide 9 mm
	MX102402	1	Strap Guide 12 mm
	MX102403	1	Strap Guide 15 mm
26	MX102300	1	Strap Guide Cover
27	W703700	1	Tension Spring ESH-201
28	M07028A	1	Rail
29	M07003	1	Plate Shield
30	MX103000	1	BLOCKER

Fig. 10-1 POOL UNIT

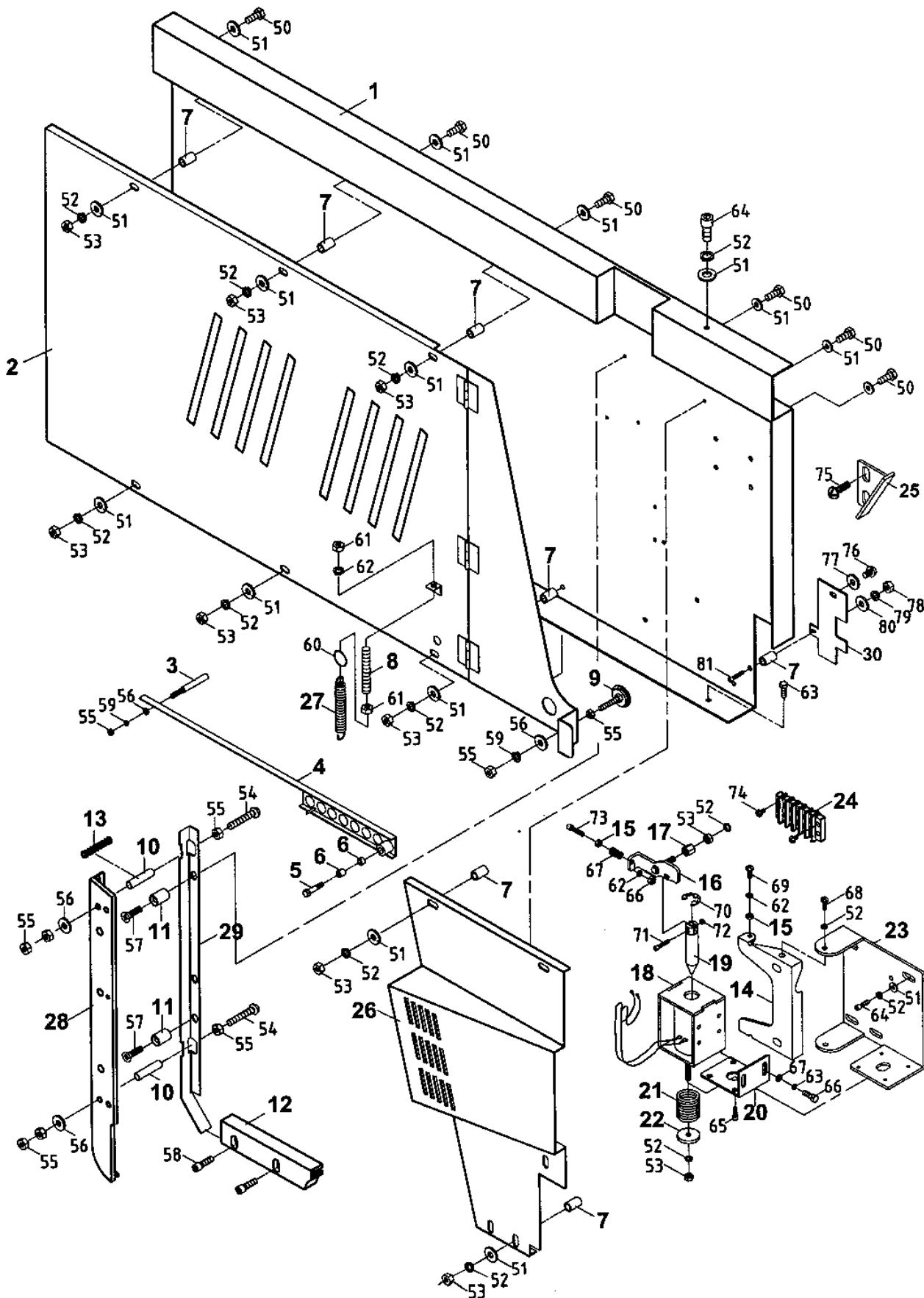

FIG. 10-1 POOL UNIT

KEY	PARTS NO.	QTY	DESCRIPTION
50	SHM6X25	10	Hex. Bolt 6 x 25
	SHM6X30	10	Hex. Bolt 6 x 30
	SHM6X35	10	Hex. Bolt 6 x 35
51	SWM6X16X2R	10	Plain Washer 6 x 16 x 2.0R
52	SSPWM6R-1	10	Spring Washer 6 mm
53	SNM6X10R	10	Hex. Nut 6 x 1.0R
54	SBM4X45	4	Phillips Head Screw 4 x 45
	SBM4X50	4	Phillips Head Screw 4 x 50
55	SNM4X07R	11	Hex. Nut 4 x 0.7R
56	SWM4X12R	6	Plain Washer 4 x 12R
57	SFM5X25	3	Screw 5 x 25
	SFM5X30	3	Screw 5 x 30
58	SLCM4X8	2	Hex. Socket Head Screw 4 x 8
59	SSPWM4R	2	Spring Washer 4 mm
60	1133-00	1	Ring
61	SNM5X08R	2	Hex. Nut 5 x 0.8R
62	SSPWM5R	1	Spring Washer 5 mm
63	SHHM6X10R	1	Socket Head Cap Screw 6 x 10R
64	SLCM6X10R	9	Socket Head Screw 6 x 10R
65	SLCM4X14R	2	Hex. Head Screw 4 x 14R
66	SHM5X10	2	Screw 5 x 10
67	SWM5X12R	2	Plain Washer 5 x 12R
68	SB1M6X10	2	Truss Head Screw 6 x 10
69	SB1M5X10	2	Truss Head Screw 5 x 10
70	RE-15	1	Ring E-15
71	SSCM3X20	1	Socket Head Cap Screw 3 x 20
72	SSNM3X05	1	Nut 3 mm (Stainless Steel)
73	SLCM5X20	1	Socket Head Cap Screw 5 x 20
74	SXBWM4X15R	2	Cross Screw 4 x 15R
75	SXBWM4X12R	2	Cross Screw with Waher 4 x 12R
76	SCM6X16R	1	Socket Head Cap Screw 6 x 16
77	SWM6X16X2R	2	Plain Washer 6 x 16X2R
78	SNM4X0.7R	1	Hex. Nut 4 x 0.7R
79	SSPWM4	1	Spring Washer 4 mm
80	SWM4X10R	1	Plain Washer 4 x 10R
81	SLCM4X30R	1	Socket Head Cap Screw 4 x 30

Fig. 11 REEL UNIT

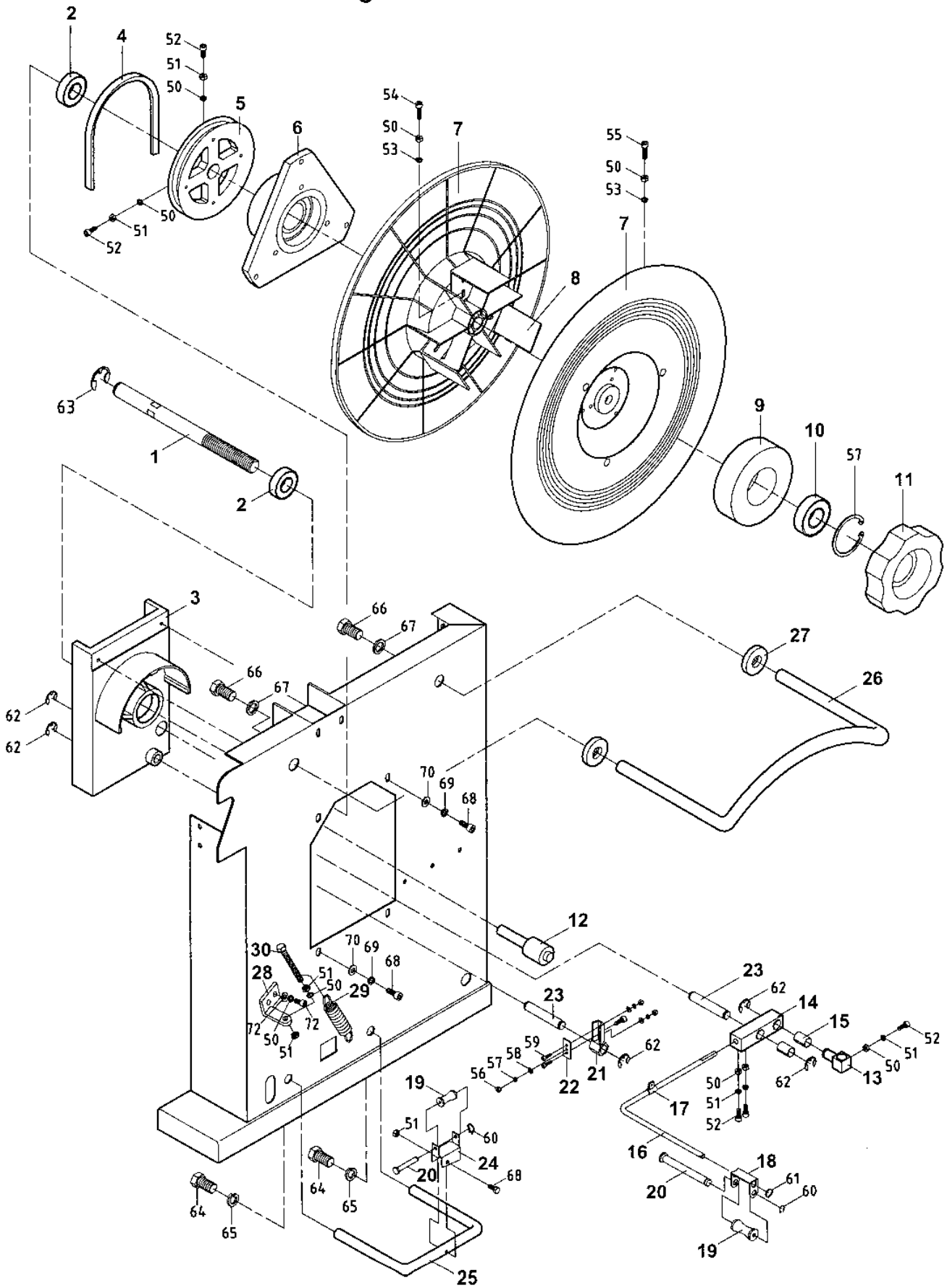
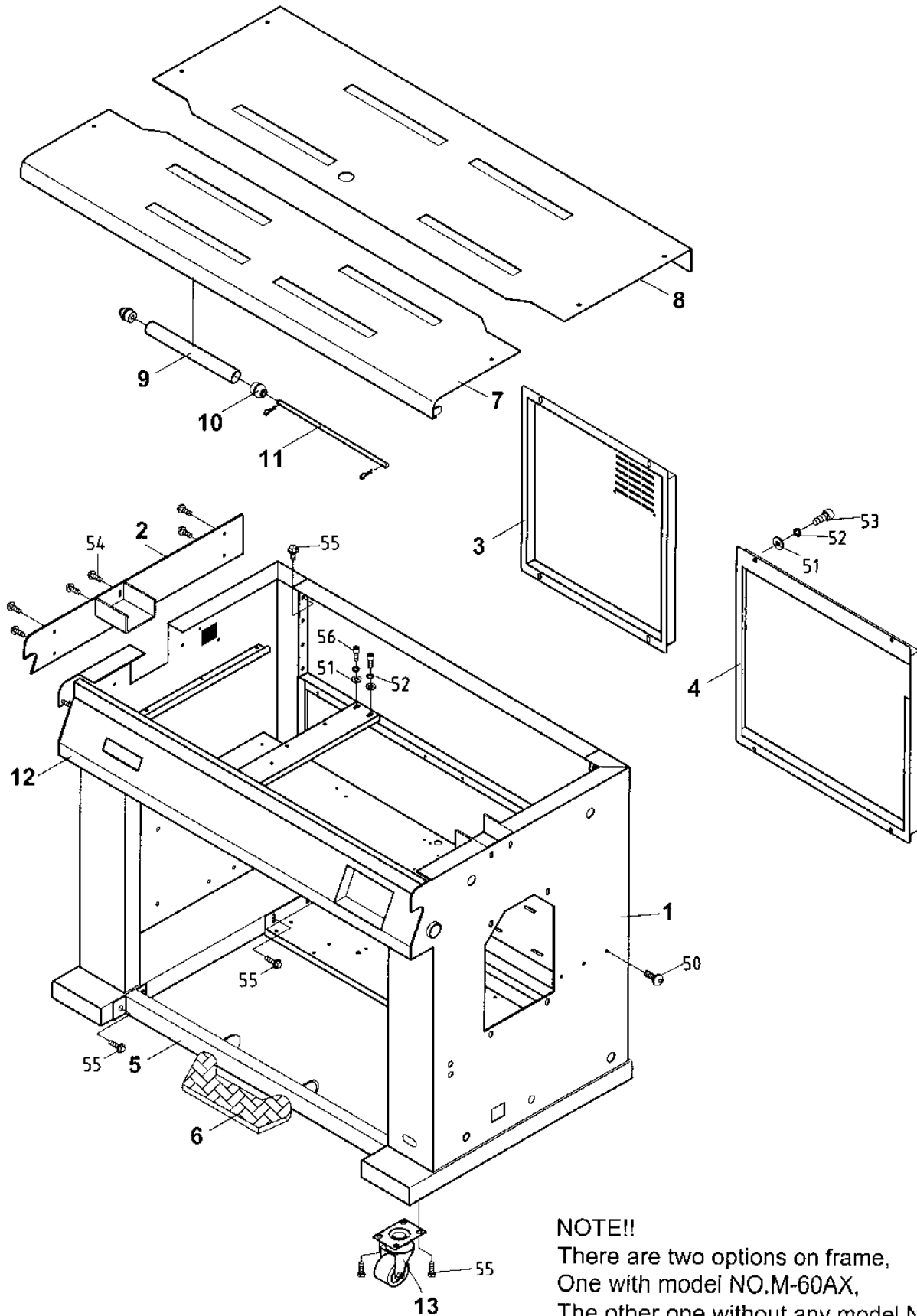

FIG. 11 REEL UNIT

KEY	PARTS NO.	QTY	DESCRIPTION
1	1107-04	1	Reel Shaft
2	2201-02B	2	Ball Bearing 6205ZZ
3	1101-01A	1	Reel Unit Base
4	1126-01	1	Brake V-Belt (Green)
5	1103-01	1	Reel Brake Pulley (Aluminum)
6	1102-02	1	Triangle Dispenser Brake Seat (PPR)
7	QL-101	2	Dispenser ABS Substance
8	QL-102	3	Inside Dispenser Shell (Black)
9	QL-901	1	Reel Holder
10	Q-1048A	1	Ball Bearing 6204ZZ
11	QL-103	1	Reel Handle
12	1111-04	1	Brake Holder
13	1106-02	1	Brake Belt Tightener
14	1105-00	1	Brake Tension Holder
15	2202-01	2	Metal Bush MB1525
16	1111-02	1	Brake Arm
17	1111-AS1	1	Brake Spring Adj. Assembly
18	1113-01	1	Roller Barcket (Stainless Steel) (A+B)
19	1115-00	1	Brake Roller
20	J-11-11-1	1	Brake Roller Shaft 6Ø x 54L
21	1104-04	1	Brake Belt Guard
22	J-17-20	1	Brake Belt Fixed Plate
23	1109-01	1	Holder Shaft
24	1112-00A	1	Angle Roller Bracket
25	1123-01	1	Reel Guard (Down)
26	1122-01	1	Reel Guard (Upper)
27	1224-02	2	Reel Guard Plate
28	1101-01-04	1	Brake Spring Adj. Seat
29	1034-01	1	Pool Spring 15 mm
30	1101-01-3	1	Spring Adj. Screw
50	SSPWM6R-1	19	Spring Washer 6 mm
51	SNM6X10R	7	Hex. Nut 6 x 1.0R
52	SLCM6X20R	10	Socket Head Cap Screw 6 x 20R
53	SWIM6	4	Washer 6 mm
54	SLCM6X30R	6	Hex. Socket Head Cap Screw 6 x 30R
55	SLCM6X25R	3	Hex. Socket Head Cap Screw 6 x 25R
56	SNM4X07R	3	Hex. Nut 4 x 0.7R
57	SSPWM4R	3	Spring Washer 4 mm
58	SWM4X10R	3	Plain Washer 4 x 10R
59	SLCM4X25	3	Socket Head Cap Screw 4 x 25
60	RE-6	2	Ring E-6
61	1133-00	1	Ring
62	RE-12	4	Ring E-12
63	RE-19	1	Ring E-19
64	SHM14X25R	2	Hex. Bolt 14 x 25R
65	SSPWM14R	2	Spring Washer 14 mm
66	1122-03	2	Hex. Bolt M18
67	SSPWM18R	2	Spring Washer 18 mm
68	SLCM8X20R	4	Socket Head Cap Screw 8 x 20R
69	SSPWM8R	4	Spring Washer 8 mm
70	SWM8X18X2R	4	Plain Washer 8 x 18 x 2.0R
71	SWM6X16R	2	Plain Washer 6 x 16 x 1.0R
72	SLCM6X10R	2	Hex. Socket Head Cap Screw 6 x 10R

**Fig. 12 BODY UNIT**



**NOTE!!**  
 There are two options on frame,  
 One with model NO.M-60AX,  
 The other one without any model NO.

**FIG. 12 BODY UNIT**

<b>KEY</b>	<b>PARTS NO.</b>	<b>QTY</b>	<b>DESCRIPTION</b>
1	MX120300	1	Frame
2	MX121000	1	Protective Plate (Left)
3	MX121100	1	Rear Panel (Left)
4	MX121200	1	Rear Panel (Right)
5	MX120700	1	Supporter of Foot Pedal
6	MX120600	1	Foot Pedal
7	MX120200	1	Upper Table (Front)
8	MX120100	1	Upper Table (Back)
9	1222-00	8	Table Roller 25.4 Ø x 220L
10	1234-01A	16	Roller Holder
11	1222-04	8	Roller Shaft
12	MX120800	1	Front Panel (Without any Model No.)
	MX120900	1	Front Panel (with Model No.: M-60AX)
13	1226-03	4	Wheel Swivel LPS-3" PU
50	SBHH6X10	3	Screw 6 x 10
51	SWM6X16R	16	Plain Washer 6 x 16R
52	SSPWM6R-1	16	Spring Washer 6 mm
53	SLCM6X10R	8	Socket Screw 6 x 10R
54	SB1M6X16	4	Truss Head Screw 6 x 16
55	SHHM6X10R	20	Socket Head Cap Screw 6 x 10R
56	SLCM6X20R	8	Socket Head Cap Scrw 6 x 20R
57	SSB1M6X10	6	Truss Head Screw 6 x 10 (Stainless Steel)

**NOTE:** There are two options on frame. One with model No.: M-60AX.  
The other one without any model No.



Fig. 13 ELECTRIC UNIT

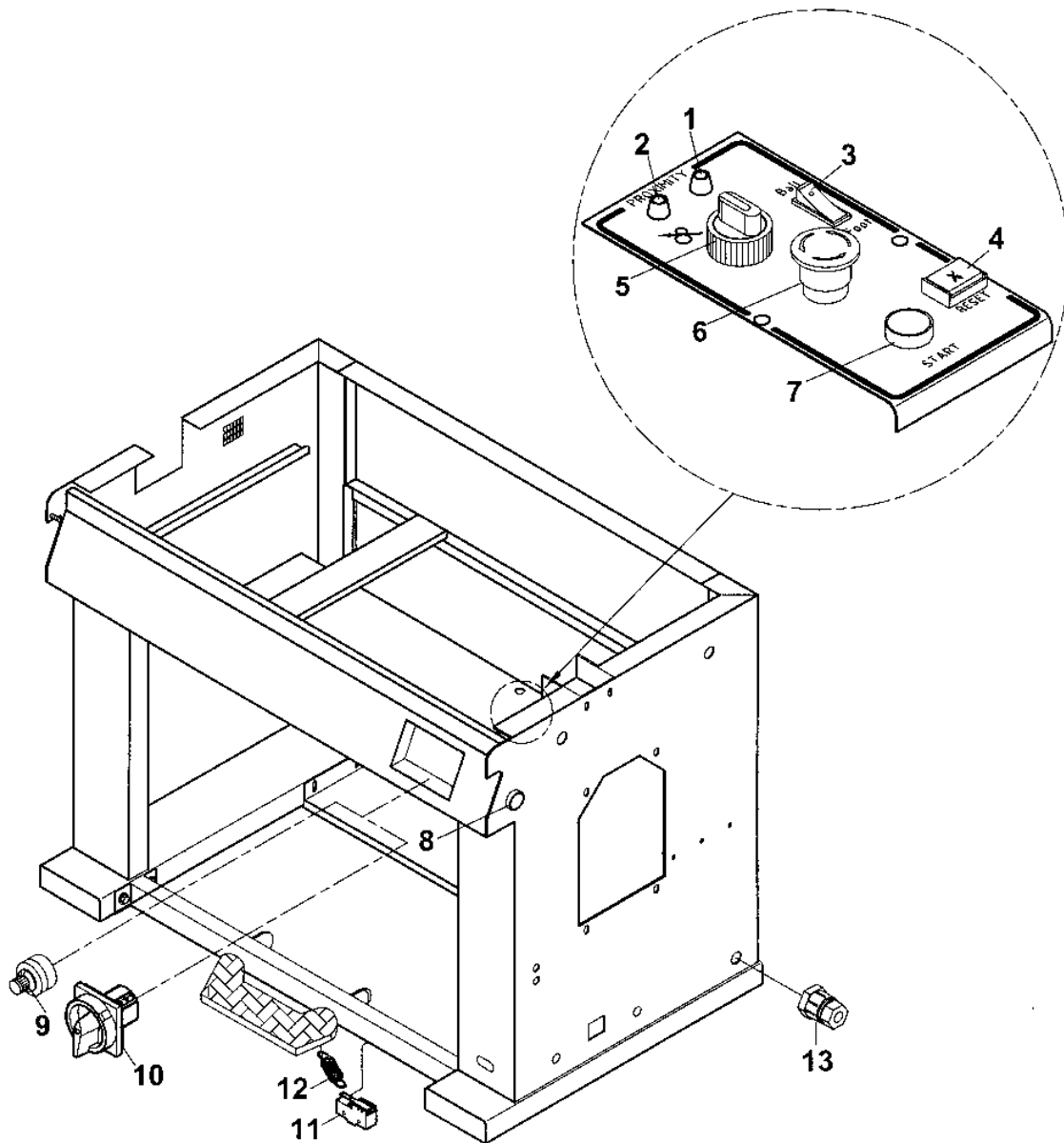

**FIG. 13 ELECTRIC UNIT**

<b>KEY</b>	<b>PARTS NO.</b>	<b>QTY</b>	<b>DESCRIPTION</b>
1	KSW-67	1	Indicator Lamp (Red) (LED) DC-24V
2	KSW-68	1	Indicator Lamp (Green) (LED) DC-24V
3	MX130300	1	Switch RH130-3
4	KSW-42	1	Reset Button (Blue) DC-24V
5	1330-01A	1	Toggle Switch (Forward / Reverse)
6	1407-20	1	Emergency Stop Switch (Red)
7	1407-17B	1	Start Button(Green)
8	1407-17	1	Insert Button (Green)
9	KR-VR-30YN-2	1	VR RV30YN-20S B303
10	1327-00	1	Main Power Switch (3PH)
	KSW-41	1	Main Power Switch (1PH)
11	1338-01A	1	Limit Switch
12	MX130200	2	Spring
13	1308-01	1	Cord Connector

Fig. 14 CONTROL BOX UNIT (M60AX)

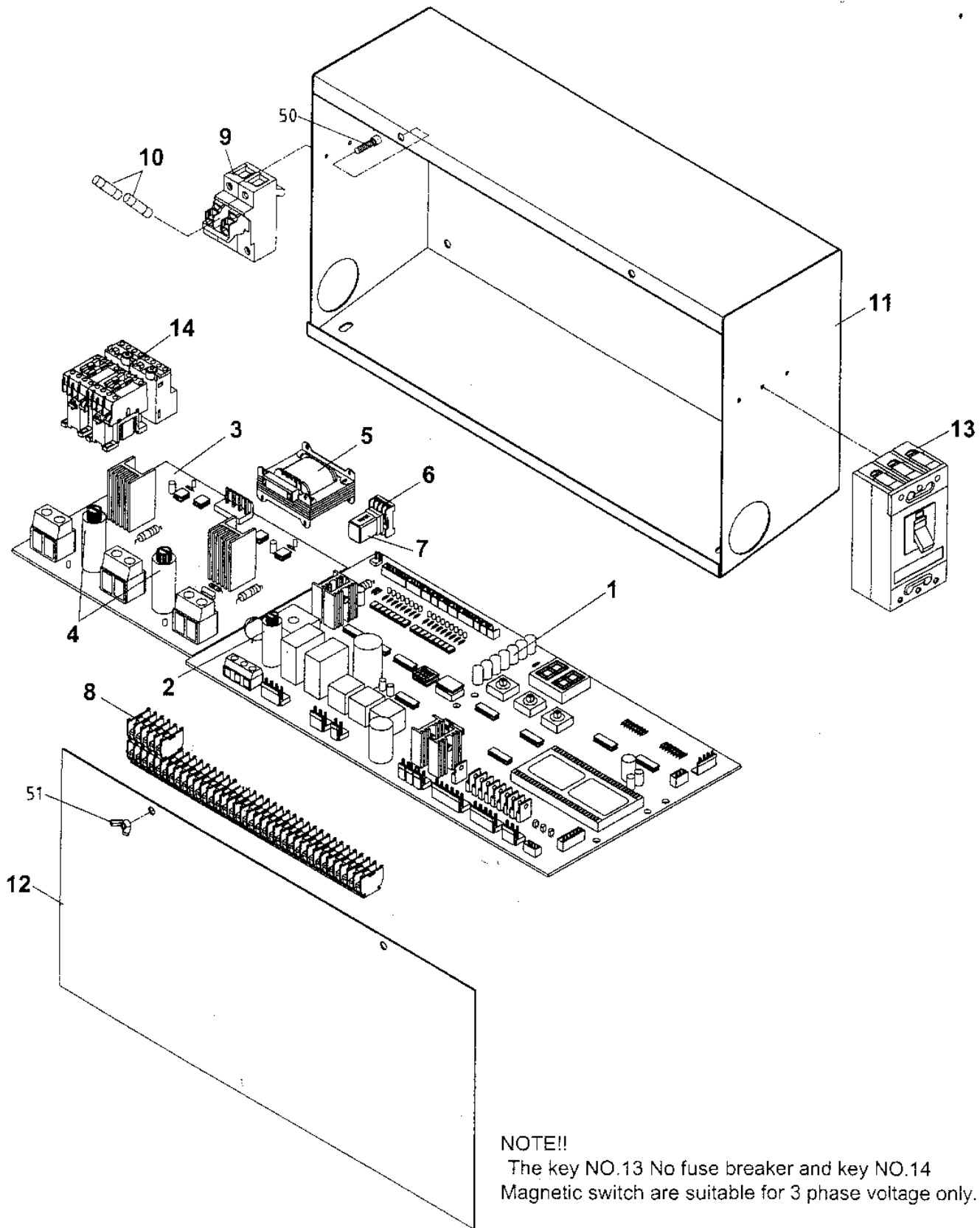

**NOTE!!**

The key NO.13 No fuse breaker and key NO.14 Magnetic switch are suitable for 3 phase voltage only.

**FIG. 14 ELECTRICAL CONTROL UNIT**

<b>KEY</b>	<b>PARTS NO.</b>	<b>QTY</b>	<b>DESCRIPTION</b>
1	MX140400	1	Main P.C. Board Assembly
2	KFS-2-5A	1	Fuse 20 mm
3	MX140500	1	P.C. Board Assembly (SSR)
4	KFS-2-10A-2	2	Fuse 10A 20 mm(220V)
	KFS-2-12A	2	Fuse 12A 20 mm(110V)
5	MX140300	1	Transformer
6	1427-08	1	Relay Seat
7	1427-31B	1	Relay
8	KAD-09-04	1	Terminal Bracket 10A 600V
9	1337-05	1	Fuse Seat
10	1337-09	2	Fuse 10 x 38 10A (380V/415V)
	1337-10	2	Fuse 10 x 38 25A (110V)
	1337-04	2	Fuse 10 x 38 16A (220V/240V)
11	MX140100	1	Control Box
12	MX140200	1	Control Box Cover
※ 13	1307-16	1	No Fuse Breaker
※ 14	1402A-AS2	2	Magnetic Swtich (220V 3PH)
	1402A-AS1	2	Magnetic Switch (380V/415V/440V 3PH)
50	SLCM6X20R	2	Socket Head Cap Screw 6 x 20R
51	SNI6R	2	Screw Nut 6 mm

**Note!!**

The key No. 13 No Fuse Breaker and Key No. 14 Magnetic Switch are suitable for 3 Phase Voltage only.